

Henry Pratt
Rectangular
Butterfly Valve



Operation and
Maintenance Manual

Job Name: _____

Contractor: _____

Date: _____

Henry Pratt Rectangular Butterfly Valve

SAFETY MESSAGES

All safety messages in the instructions are flagged with an exclamation symbol and the word “Warning”. These messages indicate procedures that must be followed exactly to avoid equipment damage, physical injury, or death. Safety labels on the product indicate hazards that can cause equipment damage, physical injury, or death.



WARNING

Personnel involved in the installation or maintenance of valves should be constantly alert to potential emission of pipeline material and take appropriate safety precautions. Always wear suitable protection when dealing with hazardous pipeline materials.

PARTS

Order parts from your local Henry Pratt sales representative or directly from Henry Pratt Company. When ordering parts, please include the serial number located on the valve tag.

WARRANTY ISSUE

Seller warrants that, at its option, it will repair, replace, or refund the unit purchase price of any products which are non-conforming due to Seller’s material or workmanship during the warranty period. The warranty period shall be twelve (12) months for parts and eighteen (18) months for all other goods after date of shipment. This shall be Buyer’s sole remedy. In order to maintain this product warranty, Buyer must give written notice to Seller’s Field Service Supervisor prior to any work being performed.

IN CONSIDERATION OF THE FOREGOING, SELLER EXCLUDES ALL OTHER EXPRESS OR IMPLIED WARRANTIES, INCLUDING BUT NOT LIMITED TO MERCHANTABILITY AND FITNESS FOR A PARTICULAR PURPOSE.

Seller does not warrant water operated metallic cylinders against damage caused by corrosion, electrolysis or mineral deposits. In no event shall warranty include valve removal or reinstallation.



WARNING

Read all applicable directions and instructions prior to any maintenance, troubleshooting or installation



Henry Pratt Rectangular Butterfly Valve

Table of Contents

FUNCTIONAL DESCRIPTION	4
INSTALLATION	5
OPERATION	6
MAINTENANCE	7
TROUBLESHOOTING	8
CONTACTING PRATT	9
PRODUCT DRAWINGS	10

Henry Pratt Rectangular Butterfly Valve

FUNCTIONAL DESCRIPTION

Rectangular butterfly valves are designed with both three and four sided disc seating surfaces. The discs rotate 1/4 turns to provide shutoff in reservoirs and conduits. Three sided seating valves will provide tight shutoff in an open conduit. Four sided seating valves will provide tight shutoff in closed conduits and reservoirs. The valves can be used to regulate flow rate by positioning the disc between 15 and 90 degrees open.

Manually operated butterfly valves are powered with gear actuators, which convert multiple handwheel, chainwheel or nut input turns into 1/4 turn valve operation. The travel of the valve disc is limited by physical stops in the actuator housing.



WARNING

CAUTION: Forcing the handwheel, chainwheel or nut against the stops will not provide tighter shutoff of the valve and may damage the actuator. Only actuator adjustments will affect valve shutoff.

Motor operated butterfly valves are powered with gear actuators, which convert multiple motor input turns into 1/4 turn valve operation. The travel of the valve disc is limited by limit switches in the motor housing and physical stops in the actuator housing. Valve shutoff is affected by limit switch and physical stop settings.



WARNING

CAUTION: Improperly set limit switches and/or physical stops may damage the motor and/or actuator.

Hydraulically operated butterfly valves are powered with a gear box and double acting cylinder. The linear stroke of the cylinder is converted to 1/4 turn operation by the gear box. Auxiliary controls are provided to direct hydraulic power to the cylinder and to control the operating speed of the cylinder.

Henry Pratt Rectangular Butterfly Valve

INSTALLATION

Refer to the mechanical general arrangement drawings prepared for this specific valve during installation. The flow direction and actuator orientation are given on the drawing. The valve should be installed with the disc in the closed or near closed position to prevent damage to the disc edge. Insert the lifting sling through the opening of the valve to lift the frame.



WARNING

CAUTION: Do not lift the valve assembly by slinging the actuator only.

The butterfly valve should be bolted to the wall frame with a 1/4" thick soft (40 – 50 durometer) rubber gasket. Studs or bolts can be used with bevel washers on the valve side of the connection. With the valve fully mounted, the position of the actuator should be verified. If the actuator position must be changed to accommodate field problems, the factory should be contacted to provide a procedure or assistance in its change.



WARNING

ALL PERSONS WHO WILL INSTALL, OPERATE OR ADJUST THIS EQUIPMENT MUST READ THE INSTRUCTIONS AND DRAWINGS CAREFULLY. INJURY AND PROPERTY DAMAGE MAY OCCUR FROM IMPROPER USE. IT IS UNDERSTOOD THAT THIS EQUIPMENT WILL BE INSTALLED BY INDIVIDUALS WITH KNOWLEDGE AND SKILLS IN ELECTRICAL EQUIPMENT. THE MANUFACTURER CANNOT BE RESPONSIBLE FOR THE MISUSE OF THIS INFORMATION OR EQUIPMENT, NOR CAN IT ASSUME ANY RESULTANT LIABILITY.

Henry Pratt Rectangular Butterfly Valve

OPERATION

MANUAL ACTUATOR FUNCTION AND USE

The manually operated rectangular butterfly valves are operated by rotating the handwheel, chainwheel, or nut. The actuator is equipped with gearing to convert the many turns into 1/4 turn operation. Inside actuator stops that limit the travel of the valve are pre-set at the factory. Forcing the handwheel, chainwheel, or nut will not cause the valve to shut off any tighter and may cause damage to the gearing.

CYLINDER OPERATOR FUNCTION AND USE:

The cylinder operated rectangular butterfly valves are operated automatically by directing hydraulic pressure to either side of the power cylinder. Solenoid valves are used to direct the fluid to the cylinder ports based on electrical power signals. In cylinder actuators, the travel stops are in the cylinder so that full hydraulic pressure can be held on the cylinder at either end of travel.

MOTOR ACTUATOR FUNCTION AND USE:

The motor actuator is designed to open and close the valve through its one quarter turn of rotation. It contains gearing so that hundreds of turns of the motor or handwheel will slowly move the valve from open to close position in about 60 seconds or vice versa. Electrical controls are included in the motor actuator for local electrical control.

The output motion of the actuator is limited to about 100 degrees of output rotation by mechanical stops in the gearing. These are factory set and should not need adjustment. The actual positioning of the valve disc will be done by limit switches in the motor actuator. The switches are also set at the factory but adjustment is sometimes required if the motor unit is installed on a separate mounting base or floorstand. Detailed procedures are given in the motor manual if adjustment is needed for the mechanical stops or the limit switches. The wiring and power requirements are given on wiring diagrams included in this instruction manual. The limit switches should be set so that the disc edge is centered over the rubber seat. Do not allow the motor actuator to torque the valve into the valve disc stops, or premature failure to the valve or motor may occur.



WARNING

All persons who will install, operate or adjust this equipment must read the instructions and drawings carefully. Injury and property damage may occur from improper use. It is understood that this equipment will be installed by individuals with knowledge and skills in electrical equipment. The manufacturer cannot be responsible for the misuse of this information or equipment, nor can it assume any resultant liability.



Henry Pratt Rectangular Butterfly Valve

MAINTENANCE

The following actions are recommended to be performed annually to ensure proper operation of your valve.

1. Cycle valve to verify operation and no interference in line.
2. Close valve and check for leakage. If leakage is found, check actuator stops to verify that the disc is fully closed. If leakage persists, inspect seat. If damage is found, contact Pratt's field service department immediately.
3. Check flange connections for leakage. Tighten bolts accordingly.
4. Check top trunnion area for shaft leakage. If leakage is detected, replace valve packing.
5. If access to line is possible, then removal of scale that may interfere with the disc travel is suggested. Also, the seat should be inspected for wear and taper pin nuts should be tight.
6. Lubrication of the valve is not required.

Henry Pratt Rectangular Butterfly Valve

TROUBLESHOOTING

PROBLEM	CAUSES	REMEDIES
Leakage between valve and actuator	<ul style="list-style-type: none"> • Packing leak 	<ul style="list-style-type: none"> • Clean packing bore and replace packing
Bottom trunnion leaks	<ul style="list-style-type: none"> • Packing or gasket 	<ul style="list-style-type: none"> • Replace bottom shaft packing, o-ring or gasket
Valve leaks when closed	<ul style="list-style-type: none"> • Disc not fully closed or past fully closed • Disc edge wear or damage • Rubber seat wear or damage • Loose debris in valve 	<ul style="list-style-type: none"> • Adjust actuator closed stop position • Clean and/or repair disc edge • Adjust or replace valve seat • Cycle valve five times to flush out debris
Valve hard to operate	<ul style="list-style-type: none"> • Foreign material in valve • Corroded operator parts • Loose actuator 	<ul style="list-style-type: none"> • Remove obstructions • Clean and grease actuator • Tighten actuator and mounting



Henry Pratt Rectangular Butterfly Valve

HOW TO CONTACT PRATT

HOW TO ORDER PARTS:

To order parts, contact our Parts Department:

Write: - Henry Pratt Company
401 South Highland Avenue
Aurora, IL 60506-5563

Attn: Parts Manager

Call - (630) 844-4144

Fax - (630) 844-4191

Please include valve serial number and description of part requested.

HOW TO OBTAIN SERVICE:

To obtain further information or secure field service, contact our Field Service Department:

Write: - Henry Pratt Company
401 South Highland Avenue
Aurora, IL 60506-5563

Attn: Field Service Manager

Call - (630) 844-4163

Fax - (630) 844-4160

Please include the following with your inquiry for service:

Henry Pratt Order Number:

Henry Pratt Item Number:

Valve Serial Number:

Type of Service Requested

Henry Pratt Rectangular Butterfly Valve

Cross Section Parts & Materials Drawing 4 Sided Rectangular BFV

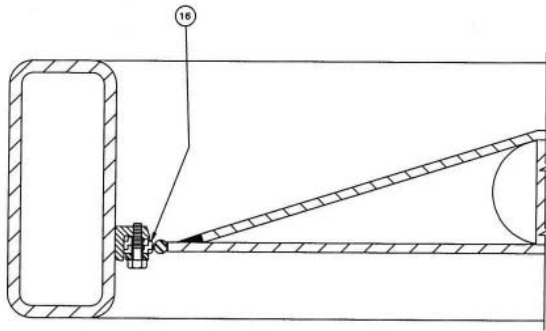

SECTION A-A

ITEM NO.	DESCRIPTION	MATERIAL
1	BODY ASSEMBLY	CARBON STEEL ASTM A-500 GRADE B
2	DISC ASSEMBLY	CARBON STEEL ASTM A-36 *
3	TOP STUB SHAFT	STAINLESS STEEL ASTM A-276 TYPE 304
4	BOTTOM STUB SHAFT	STAINLESS STEEL ASTM A-276 TYPE 304
5	TAPER PIN	STAINLESS STEEL ASTM A-276 TYPE 304
6	HEX NUT	STAINLESS STEEL TYPE 304
7	LOCKWASHER	STAINLESS STEEL TYPE 304
8	KEY	COLD DRAWN STEEL AISI C-1045
9	THRUST BEARING PLATE	BRONZE SAE 660
10	THRUST BEARING COLLAR	CARBON STEEL ASTM A-36

* WITH STAINLESS STEEL ASTM A-276 TYPE 304 EDGE

ITEM NO.	DESCRIPTION	MATERIAL
11	STUD	CARBON STEEL GRADE 2
12	BEARING	TEFLON LINED FIBERGLASS BACKED
13	HEX HEAD CAP SCREW	STN. STL. TYPE 304 Δ
14	SEGMENT RETAINER	STAINLESS STEEL ASTM A-276 TYPE 304 HOT ROLLED, ANNEALED AND PICKLED
15	BOTTOM COVER	CARBON STEEL ASTM A-36
16	SEAT	HYCAR 50-DURO
17	GASKET	CRANITE
18	SEALANT	RTV Δ
19	HEX HEAD CAP SCREW	CARBON STEEL GRADE 8 Δ
20	V-TYPE PACKING	FABRIC REINFORCED NEOPRENE OR BUNA-N
21	PACKING RETAINER RING	NYLON 101
22	PACKING RETAINER PLATE	#10 GAUGE SHEET STEEL (C-1018)

