

ACTUATOR SIZE	J	L	M	N	P	Q	R	NUMBER OF TURNS
MDT-3S	5-5/8	2-7/16	3-1/4	3-5/32	5-5/8	5-3/8	10-3/8	30
MDT-4S	6-3/8	2-27/32	3-3/8	4	7-5/16	6-3/4	11-5/16	40
MDT-5	7-9/16	3-15/32	4-1/2	5-1/2	8-3/4	10	17	44
MDT-5S	8-5/16	3-15/16	5-1/2	7	10-1/2	15-15/16	19-7/8	136
MDT-6S	10-3/16	5-1/16	7	8-1/4	12-5/8	14-3/16	26-1/2	215

VALVE SIZE	150 PSI						
	A	B	C	D	E	F	G
24	18-5/8	18-3/8	32	8	1-7/8	20-1-1/4	29-1/2
30	21-1/2	24-1/8	38-3/4	12	2-1/8	28-1-1/4	36
36	25-7/16	28	46	12	2-3/8	32-1-1/2	42-3/4
42	29-7/8	32-11/16	53	12	2-5/8	36-1-1/2	49-1/2
48	34-1/16	36-7/8	59-1/2	15	2-3/4	44-1-1/2	56
54	37-1/2	40-11/16	66-1/4	15	3	44-1-3/4	62-3/4
60	41-3/4	45-3/16	73	15	3-1/8	52-1-3/4	69-1/4
66	46-1/16	49-1/2	80	18	3-3/8	52-1-3/4	76
72	50	53-1/8	86-1/2	18	3-1/2	60-1-3/4	82-1/2

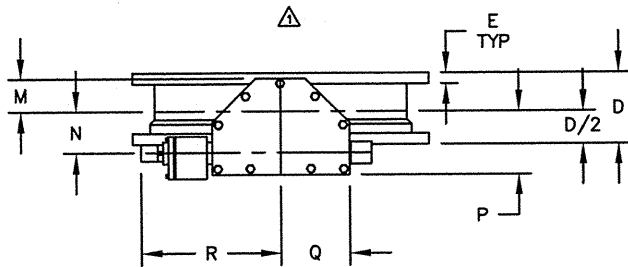

ACTUATOR POSITION 1

NOTES:

1. ALL DIMENSIONS SHOWN IN INCHES.
2. "D" DIMENSION $\pm 1/8$ ".
3. FOR BOLTS SMALLER THAN $\phi 1-3/4$, BOLT HOLES WILL BE $1/8$ " LARGER THAN DIAMETER OF BOLT. FOR BOLTS $\phi 1-3/4$ OR LARGER, BOLT HOLES WILL BE $1/4$ " LARGER THAN DIAMETER OF BOLT.
4. DIMENSIONS AND DRILLING OF END FLANGES CONFORM TO THE AMERICAN CAST IRON FLANGE STANDARDS, CLASS 125 (B16.1).
5. VALVES MANUFACTURED & TESTED IN ACCORDANCE WITH AWWA SPECIFICATION C-504 LATEST REVISION, CLASS 150B.
6. RECOMMENDATION FOR MATING FLANGES: WHERE INSULATING BUSHINGS ARE USED, IT IS NECESSARY THAT BOLT HOLES BE DRILLED OVERSIZE BY AN AMOUNT EQUAL TO TWO TIMES THE INSULATING SLEEVE THICKNESS TO MAINTAIN THE SAME MINIMUM CLEARANCE FOR BOLTS.
7. CAUTION: IT IS RECOMMENDED THAT VALVES BE INSTALLED INTO PIPING SYSTEM IN ACCORDANCE WITH AWWA M-11 TO PREVENT ANY UNDUE PIPING STRESS, DEFLECTION OR BENDING THAT MAY EFFECT THE PERFORMANCE OF THE VALVE.

BURIED SERVICE NUT

F = NO. & SIZE OF BOLTS
125# STANDARD LAYOUT
STRADDLE CENTERLINE
INCLUDES TAPPED HOLES
EACH FLANGE

TAPPED HOLES VALVE SIZE	NO. TAPPED HOLES (EACH FLANGE)
30"-72"	4-TOP; 4-BOTTOM
24"	2-TOP; 2-BOTTOM

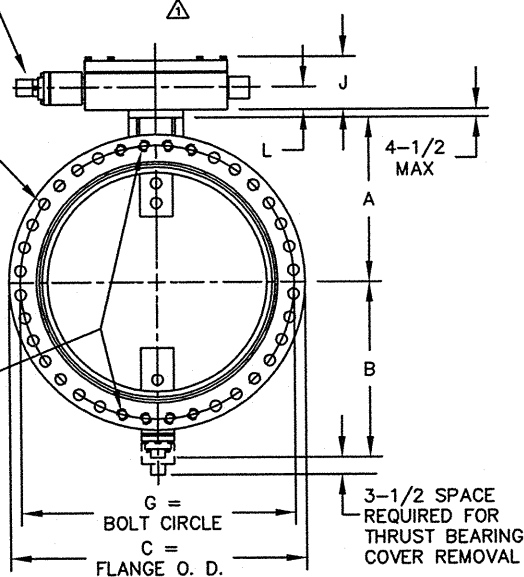

REV	DATE	BY	DESCRIPTION	APP
	03/11/10	MZ	REMOVED 25 & 75 LB. <i>rem</i>	
	9-7-05	CEG	REMOVED POSITION INDICATING ARROW	ES
				APP

PRATT HENRY PRATT COMPANY
AURORA, ILL.

TRITON XR-70 BUTTERFLY VALVE
FLANGED
MDT BURIED SERVICE NUT

SCALE NONE DATE 12/07/04
DRAWN BY BZ CHECKED BY ES
APPROVED GA=BORDER
DRWG. NO. GA-11304 REV 2 A/C