

PRATT

Henry Pratt Company

HP250II™

and HP250™



Valves for the 21st Century



A Tradition of Excellence

With the development of the first rubber seated butterfly valve more than 70 years ago, the Henry Pratt Company became a trusted name in the flow control industry, setting the standard for product quality and customer service. Today Pratt provides the following range of superior products to the water, waste water and power generation industries.

BUTTERFLY VALVES: from 3" to 162"

RECTANGULAR VALVES: 1' x 1' to 14' x 16'

BALL VALVES —

RUBBER SEATED: from 4" to 60"

METAL SEATED: from 6" to 48"

PLUG VALVES: from 1/2" to 36", 3 ways

HYDRAULIC CONTROL SYSTEMS

VALVE CONTROLS

**ENERGY DISSIPATING VALVES
AND FIXED ENERGY DISSIPATERS**

CONE VALVES

CHECK VALVES

A Commitment to Meeting The Customers' Needs

Henry Pratt valves represent a long-term commitment to both the customer and to a tradition of product excellence. This commitment is evident in the number of innovations we have brought to the industries we serve. In fact, the Henry Pratt Company was the first to introduce many of the flow control products in use today, including the first rubber seated butterfly valve, one of the first nuclear N-Stamp valves, and the bonded seat butterfly valve.

Innovative Products For Unique Applications

Though many of the standard valves we produce are used in water filtration and distribution applications, Pratt has built a reputation on the ability to develop specialized products that help customers to meet their individual operational challenges.

Creative Engineering for Fluid Systems

Pratt's ability to provide practical solutions to complex issues is demonstrated by the following case histories.

Earthquake Proof Valves

Pratt designed and manufactured hydraulically actuated valves for a water storage application so that the valves would automatically operate in the event of earthquakes. This led to the development of a valve that will withstand forces of up to 6g's.

Custom Actuation/ Isolation Valves

Pratt designed and manufactured valves that would isolate a working chamber in the event of a nuclear emergency during the decommissioning of armed nuclear warheads. The valves were able to close in a millisecond using specially designed Pratt electro-pneumatic actuators.

Valves Designed for Harsh Environments

Pratt designed and manufactured a 144" diameter butterfly valve for the emergency cooling system at a jet engine test facility. The valve was designed to supply water to help dissipate the tremendous heat generated by the engines during testing.

PRATT

Henry Pratt Company

Through experience, commitment and creative engineering, Pratt is uniquely suited to provide superior products for our customers' special needs. For more information, contact our corporate headquarters in Aurora, Illinois.



401 South Highland Avenue
Aurora, Illinois 60506-5563
phone: 630.844.4000
fax: 630.844.4160
toll free: 877.436.7977
www.henrypratt.com

TABLE OF CONTENTS

PRATT HP250II™ BUTTERFLY VALVE

SCOPE OF LINE2

DESIGN AND CONSTRUCTION DETAILS2

PIPE MATING CHART2

FEATURES AND BENEFITS3

E-LOK SEATING SYSTEM3

SEAT ON BODY DESIGN ADVANTAGE4

HP250II™ SUGGESTED SPECIFICATION5

DIMENSIONAL DATA.....5-7

HP250™ BUTTERFLY VALVE

SCOPE OF LINE8

HP250™ SUGGESTED SPECIFICATION8

DIMENSIONAL DATA9

SCOPE OF THE LINE: PRATT HP250II™ BUTTERFLY VALVE

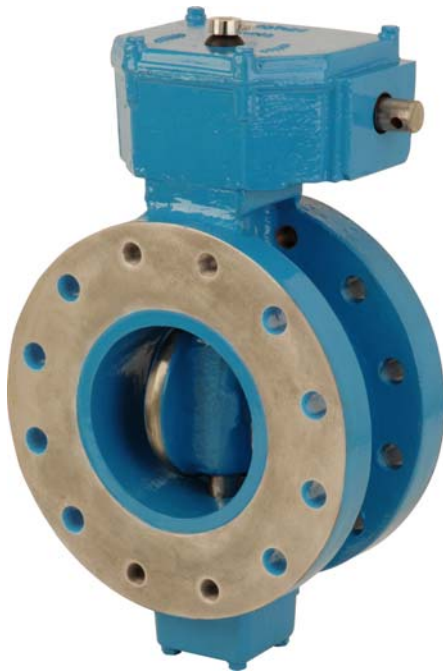

Sizes: 3" through 20" Bonded Seat
24" through 48" E-Lok Seat

Body Styles: End connections

- Flanged
- Mechanical Joint
- Flanged x Mechanical Joint

Pressure Class:

- AWWA 250 B

Actuation Options*:

- Nut
- Handwheel
- Buried Service

*Consult factory for other end connections and actuation options

DESIGN AND CONSTRUCTION

- Ductile iron valve body
- Stainless steel shaft
- Ductile iron disc
- Rubber seat

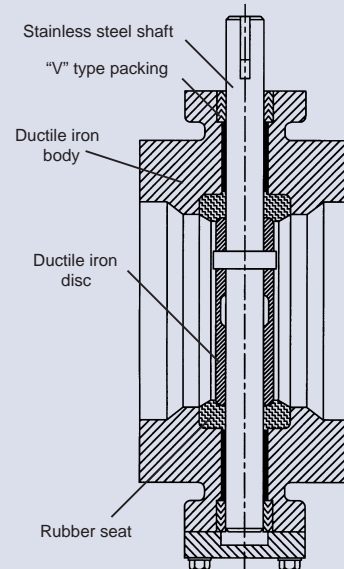

MATING CHART

| | Steel | Cast Iron/Ductile Iron |
|----------|--|---|
| HP250™ | AWWA C207-01 Class F | ANSI B16.1 Class 250 |
| HP250II™ | AWWA C207-01 Class B Class D Class E MSS Sp-44 Steel C1.150 ASME B16.47-96 Steel C1.150 Series A | ANSI B16.1 Class 150 AWWA C110 Class 125 |

HP250II™ BUTTERFLY VALVE

| FEATURE | BENEFIT |
|---|--|
| ■ Higher Pressures | ■ Working pressures to 250 psi with temperatures to 150° F. |
| ■ Wide Size Range | ■ Available in sizes 3" - 72" (flanged ends); 6" - 48" (mechanical joint ends). |
| ■ Low Seating/Unseating Torques | ■ Increases seat life and reduces actuator size. |
| ■ Unique Disc Design | ■ Provides more strength, less weight, and greater free-flow area than conventional disc designs. |
| ■ Adjustable/Replaceable Seat on 24" and larger | ■ Patented E-LOK® design retains seat in body without metal hardware. If adjustable or replacement is required, both can be done in the field utilizing simple hand tools. |
| ■ Choice of Valve Ends | ■ Flange and Mechanical Joint. Flanges are in full accordance with ANSI B16.1, Class 125# cast iron flanges where applicable. Mechanical joint ends conform to ANSI 21.11. For ANSI Class 250# Flange, see page 8. |
| ■ Actuators and Accessories | ■ Available with manual traveling nut or worm gear, electric motor or cylinder actuators; plus full range of extensions, indicators, positioners, remote controls and other accessories. |

A PROVEN STANDARD FOR BUBBLE-TIGHT CLOSURE...

The patented E-LOK® seating system features a rubber seat that provides multiple sealing lines which permit higher levels of radial compression. The multiple ridges are designed to reduce rubber stress levels for lower seating torques and better seating action. Unique epoxy injection process locks the seat against the disc with uniform pressure control around the entire periphery to provide a bubble-tight seal. Design also allows easy seat replacement without removing the valve from the line where possible.

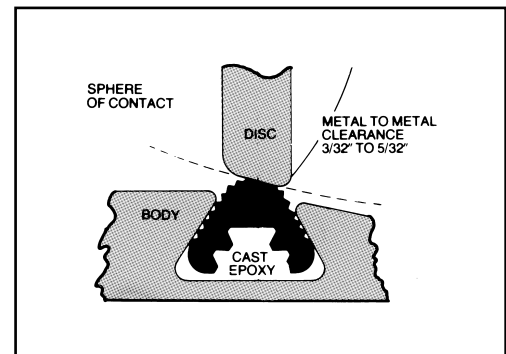

THE HENRY PRATT SEAT ON BODY DESIGN ADVANTAGE

A key aspect of butterfly valve design relates to location of the rubber seat. Essentially the seat can be positioned on the body or on the disc per AWWA C504.

But the sum of Pratt design, testing, and field experience has proven conclusively that **seat on body design is preferred** because it provides maximum reliability.

The **major advantage of seat on body design** is that the risk of damage to the rubber seat is minimized because the sealing edge of the disc is much harder than any corrosion deposits built up within the valve body or pipeline. (See Figures 1 and 2) This is important because build up can interfere with the swing radius of the disc. Additionally, seats on body are recessed and thus more protected than seat on disc designs.

Seat on disc designs are much more susceptible to damage because it is the relatively soft rubber seat on the disc that comes into contact with corrosion deposits and build up. Also any solid materials flowing in the fluid can impinge on a rubber seat located on the disc. (See Figure 3)

Another disadvantage of seat on disc design is that since the maximum velocity in a pipeline occurs at the upstream and downstream leading edges of the disc, the rubber seat on disc designs are much more susceptible to wear, vibration and potential loosening of hardware.

Conclusion: Henry Pratt seat on body designs which do not depend on retaining hardware in the waterway for seat retention have recognized these potential problems and addressed them in advance. Successful field performance has substantiated the credibility of this design approach!!

Pratt – Rubber Seat on Body Designs

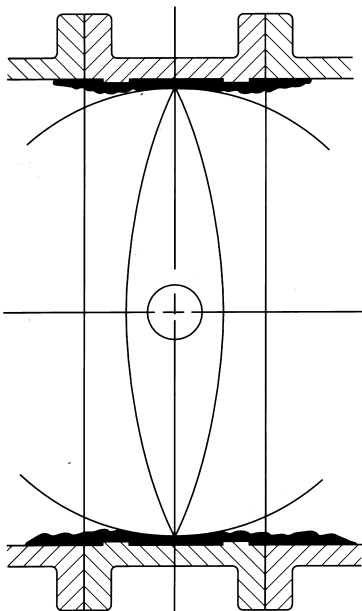

FIGURE 1

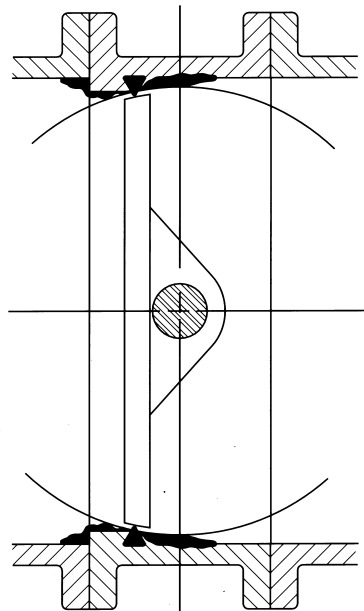

FIGURE 2

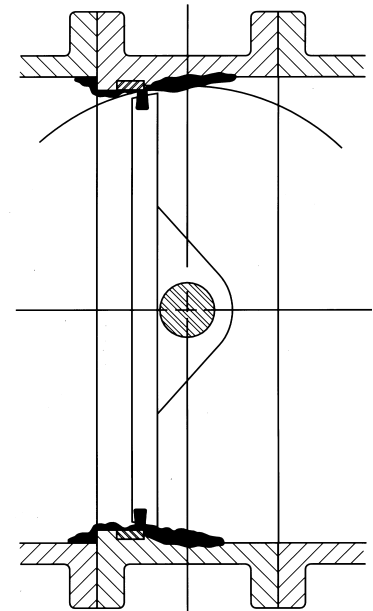

FIGURE 3

Rubber Seat on Disc Design by Others

HP250II™ BUTTERFLY VALVE, 125# FLANGED & MJ SPECIFICATION

General

Butterfly valves shall be manufactured in accordance with the latest revision of AWWA Standard C504 Class 250B, shall be suitable for a differential pressure of 250 psig, and be certified to NSF Standard 61. Valves shall be Henry Pratt Model HP250+ and comply with the following details:

Valve Bodies

The body shall be constructed of Ductile Iron ASTM A536 Gr. 65-45-12, with flanged end connections drilled in accordance with ANSI B16.1, Class 125, Class 250, or Mechanical Joint ends. The body wall thickness shall be in strict accordance with AWWA C504.

Valve Shafts

The shaft shall be made of ASTM A-564 Type 630 condition H-1150. The shaft seals shall be "V" type packing. Shaft seals shall be of a design allowing replacement without removing the valve shaft. No O-ring or "U" cup packing shall be allowed. The bearing shall be a stainless steel backed Teflon material. Bearing load shall not exceed 1/5 of the compressible strength of the bearing or shaft material.

Valve Discs

The disc shall utilize an on-center shaft and symmetrical design, cast from Ductile Iron ASTM A536 Gr. 65-45-12. The disc edge shall be stainless steel type 316. Disc shall be retained by pins that extend through the full diameter of the shaft. The pin material shall be the same as the shaft material. Torque plugs or tangential fasteners shall not be allowed. For valve sizes 3" through 20" the rubber seat shall be of one piece construction, simultaneously molded and bonded directly into the body. The seat material shall be either Buna-N or EPDM rubber.

Valve Actuators

Manual actuators shall be of the traveling nut, self-locking type and shall be designed to hold the valve in any intermediate position between fully open and fully closed without fluttering or creeping. The actuator shall have mechanical stops that will withstand and input torque of 450 ft/lb. against each stop. Manual actuators shall conform to AWWA Standard C504 and shall be Pratt MDT or an approved equal.

HP250II™ 6"-16", DUCTILE IRON BODY, FLANGED x MJ

| Valve Size | A | B | C | CC | D | DD | E | EE | F | FF | G | GG | X |
|------------|--------|--------|--------|----------|--------|--------|--------|--------|--------|--------|--------|--------|---------|
| 6 | 6-1/2 | 5-1/8 | 11 | 11 | 6-3/4 | 4-1/4 | 1-1/16 | 1-1/16 | 8-3/4 | 6-3/4 | 9-1/2 | 9-1/2 | 4-1/4 |
| 8 | 7-3/4 | 6-1/2 | 13-1/2 | 13-1/4 | 7-5/16 | 4-5/16 | 1-1/8 | 1-1/8 | 8-3/4 | 6-3/4 | 11-3/4 | 11-3/4 | 4-13/16 |
| 10 | 9 | 9-7/8 | 16 | 15-9/16 | 8-5/8 | 4-5/8 | 1-1/4 | 1-3/16 | 12-7/8 | 8-3/4 | 14-1/4 | 14 | 6-1/8 |
| 12 | 10-1/2 | 11-3/8 | 19 | 17-15/16 | 8-5/8 | 4-5/8 | 1-1/4 | 1-1/4 | 12-7/8 | 8-3/4 | 17 | 16-1/4 | 6-1/8 |
| 16 | 13-1/2 | 14-3/8 | 23-1/2 | 22-9/16 | 10 | 6 | 1-7/16 | 1-3/8 | 16-1 | 12-3/4 | 21-1/4 | 21 | 6-1/2 |

| Actuator Size | J | L | M | N | P | Q | R | Number of Turns |
|---------------|---------|---------|-------|--------|--------|-------|---------|-----------------|
| MDT-2S | 4-11/16 | 2 | 2-1/8 | 2 | 4-1/2 | 4-1/2 | 8-1/4 | 32 |
| MDT-3S | 5-5/8 | 2-7/16 | 3-1/4 | 3-5/32 | 5-5/8 | 5-3/8 | 10-3/8 | 30 |
| MDT-4S | 6-3/8 | 2-27/32 | 3-3/8 | 4 | 7-5/16 | 6-3/4 | 11-5/16 | 40 |

NOTES:

- ALL DIMENSIONS SHOWN IN INCHES.
- "D" DIMENSION $\pm 1/16"$ FOR 6" THRU 10" VALVES. "D" DIMENSION $\pm 1/8"$ FOR 12" THRU 20" VALVES.
- FOR BOLTS SMALLER THAN 01-3/4, BOLT HOLES WILL BE 1/8" LARGER THAN DIAMETER OF BOLT. FOR BOLTS 01-3/4 OR LARGER, BOLT HOLES WILL BE 1/4" LARGER THAN DIAMETER OF BOLT.
- DIMENSIONS AND DRILLING OF END FLANGE CONFORM TO THE AMERICAN CAST IRON FLANGE STANDARDS, CLASS 125 (B16.1).
- DIMENSIONS AND DRILLING OF MECHANICAL JOINT END CONFORM TO ANSI/AWWA C111/A21/11.
- VALVES MANUFACTURED & TESTED IN ACCORDANCE WITH THE AWWA SPECIFICATION C504 LATEST REVISION, CLASS 250B.
- RECOMMENDATION FOR MATING FLANGES: WHERE INSULATING BUSHINGS ARE USED, IT IS NECESSARY THAT BOLT HOLES BE DRILLED OVERSIZE BY AN AMOUNT EQUAL TO TWO TIMES THE INSULATING SLEEVE THICKNESS TO MAINTAIN THE SAME MINIMUM CLEARANCE FOR BOLTS.

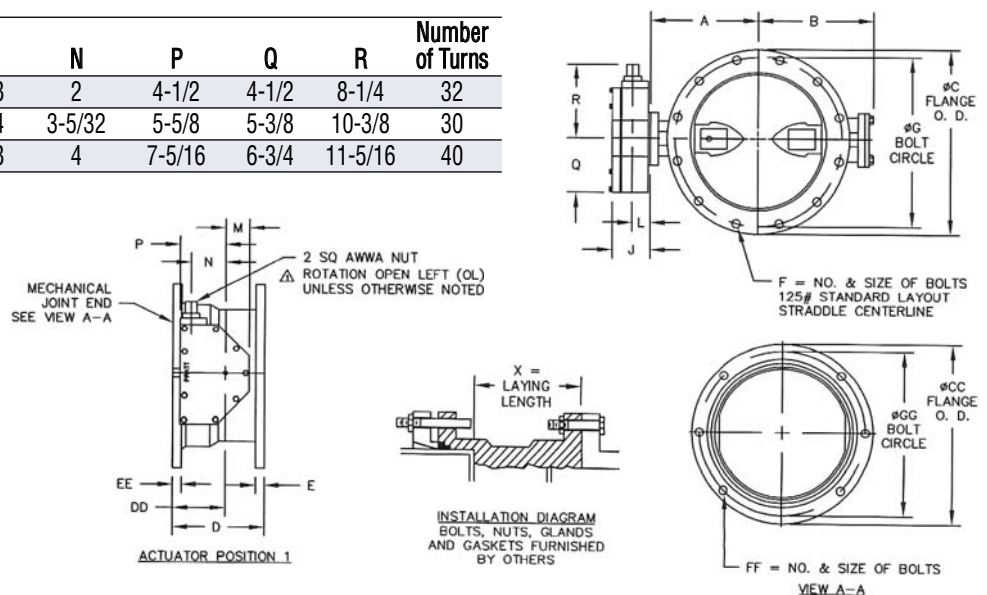

HP250II™ 3"- 20", DUCTILE IRON BODY, ANSI 125# FLANGED ENDS

| Actuator Size | Valve Size | J | L | M | N | P | Q | R | Number of Turns |
|---------------|------------|---------|---------|-------|--------|--------|-------|---------|-----------------|
| MDT-2S | 3-8" | 4-11/16 | 2 | 2-1/8 | 2 | 4-1/2 | 4-1/4 | 8-1/4 | 32 |
| MDT-3S | 10-14" | 5-5/8 | 2-7/16 | 3-1/4 | 3-5/32 | 5-5/8 | 5-3/8 | 10-3/8 | 30 |
| MDT-4S | 16&18" | 6-3/8 | 2-27/32 | 3-3/8 | 4 | 7-5/16 | 6-3/4 | 11-5/16 | 40 |
| MDT-5 | 20" | 7-9/16 | 3-15/32 | 4-1/2 | 5-1/2 | 8-3/4 | 10 | 17 | 44 |

| Valve Size | A | B | C | D | E | F | G |
|------------|--------|----------|--------|---|---------|----------|--------|
| 3 | 4-3/4 | 3-3/4 | 7-1/2 | 5 | 3/4 | 4-5/8 | 6 |
| 4 | 5-1/2 | 4-1/2 | 9 | 5 | 15/16 | 8-5/8 | 7-1/2 |
| 6 | 6-1/2 | 5-1/2 | 11 | 5 | 1 | 8-3/4 | 9-1/2 |
| 8 | 7-3/4 | 6-3/4 | 13-1/2 | 6 | 1-1/8 | 8-3/4 | 11-3/4 |
| 10 | 9 | 9-11/16 | 16 | 8 | 1-3/16 | 12-7/8 | 14-1/4 |
| 12 | 10-1/2 | 11-3/16 | 19 | 8 | 1-1/4 | 12-7/8 | 17 |
| 14 | 11-7/8 | 12-9/16 | 21 | 8 | 1-3/8 | 12-1 | 18-3/4 |
| 16 | 13-1/2 | 14-3/16 | 23-1/2 | 8 | 1-7/16 | 16-1 | 21-1/4 |
| 18 | 14-3/8 | 15-1/16 | 25 | 8 | 1-9/16 | 16-1-1/8 | 22-3/4 |
| 20 | 16 | 16-11/16 | 27-1/2 | 8 | 1-11/16 | 20-1-1/8 | 25 |

NOTES:

- ALL DIMENSIONS SHOWN IN INCHES.
- "D" DIMENSION $\pm 1/16"$ FOR 3" THRU 10" VALVES.
"D" DIMENSION $\pm 1/8"$ FOR 12" THRU 20" VALVES.
- FLANGE THROUGH BOLT HOLES WILL BE 1/8" LARGER THAN DIAMETER OF BOLT.
- DIMENSIONS AND DRILLING OF END FLANGES CONFORM TO THE AMERICAN CAST IRON FLANGE STANDARDS, CLASS 125 (B16.1).
- VALVES MANUFACTURED & TESTED IN ACCORDANCE WITH THE AWWA SPECIFICATION C504 LATEST REVISION, CLASS 250B.
- RECOMMENDATION FOR MATING FLANGES: WHERE INSULATING BUSHINGS ARE USED, IT IS NECESSARY THAT BOLT HOLES BE DRILLED OVERSIZE BY AN AMOUNT EQUAL TO TWO TIMES THE INSULATING SLEEVE THICKNESS TO MAINTAIN THE SAME MINIMUM CLEARANCE FOR BOLTS.

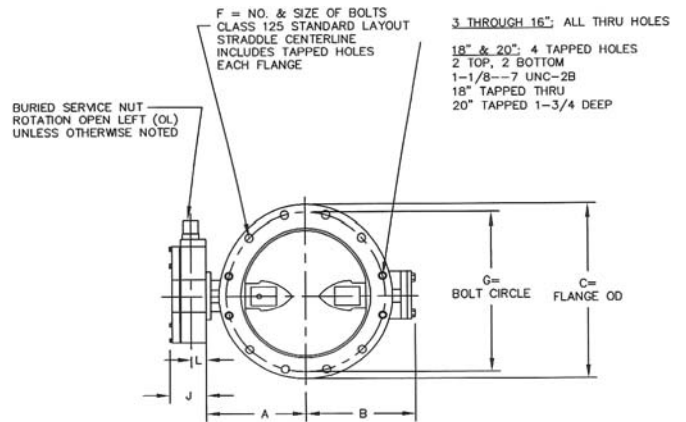
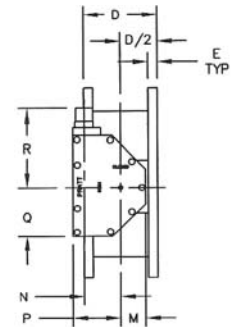

HP250II™ 24"- 48", DUCTILE IRON BODY, ANSI 125# FLANGED ENDS

| Actuator Size | J | L | M | N | P | Q | R | Number of Turns |
|---------------|--------|---------|-------|-------|--------|----------|--------|-----------------|
| MDT-5 | 7-9/16 | 3-15/32 | 4-1/2 | 5-1/2 | 8-3/4 | 10 | 17 | 44 |
| MDT-5S | 8-5/16 | 3-15/16 | 5-1/2 | 7 | 10-1/2 | 15-15/16 | 19-7/8 | 136 |
| MDT-6S | 9-7/8 | 5-1/16 | 7 | 8-1/4 | 12-5/8 | 14-3/16 | 26-1/2 | 215 |

| Valve Size | A | B | C | D | E | F | G |
|------------|---------|----------|--------|----|-------|----------|--------|
| 24 | 18-5/8 | 18-3/8 | 32 | 8 | 1-7/8 | 20/1-1/4 | 29-1/2 |
| 30 | 21-1/2 | 24-1/8 | 38-3/4 | 12 | 2-1/8 | 28/1-1/4 | 36 |
| 36 | 25-7/16 | 28 | 46 | 12 | 2-3/8 | 32/1-1/2 | 42-3/4 |
| 42 | 29-7/8 | 32-11/16 | 53 | 12 | 2-5/8 | 36/1-1/2 | 49-1/2 |
| 48 | 34-1/16 | 36-7/8 | 59-1/2 | 15 | 2-3/4 | 44/1-1/2 | 56 |

NOTES:

- ALL DIMENSIONS SHOWN IN INCHES.
- "D" DIMENSION $\pm 1/8"$ FOR 24" AND LARGER VALVES.
- FOR BOLTS SMALLER THAN 01-3/4, BOLT HOLES WILL BE 1/8" LARGER THAN DIAMETER OF BOLT. FOR BOLTS 01-3/4 OR LARGER, BOLT HOLES WILL BE 1/4" LARGER THAN DIAMETER OF BOLT.
- DIMENSIONS AND DRILLING OF END FLANGES CONFORM TO THE AMERICAN CAST IRON FLANGE STANDARDS, CLASS 125 (B16.1).
- VALVES MANUFACTURED & TESTED IN ACCORDANCE WITH AWWA SPECIFICATION C504 LATEST REVISION, CLASS 250B.
- RECOMMENDATION FOR MATING FLANGES: WHERE INSULATING BUSHINGS ARE USED, IT IS NECESSARY THAT BOLT HOLES BE DRILLED OVERSIZE BY AN AMOUNT EQUAL TO TWO TIMES THE INSULATING SLEEVE THICKNESS TO MAINTAIN THE SAME MINIMUM CLEARANCE FOR BOLTS.
- CAUTION: IT IS RECOMMENDED THAT VALVES BE INSTALLED INTO PIPING SYSTEM IN ACCORDANCE WITH AWWA M-11 TO PREVENT ANY UNDE PIPING STRESS, DEFLECTION OR BENDING THAT MAY AFFECT THE PERFORMANCE OF THE VALVE.
- EXTENSION STEM CAN BE USED WITH STANDARD VALVE BOXES OR 5' SOIL PIPE.

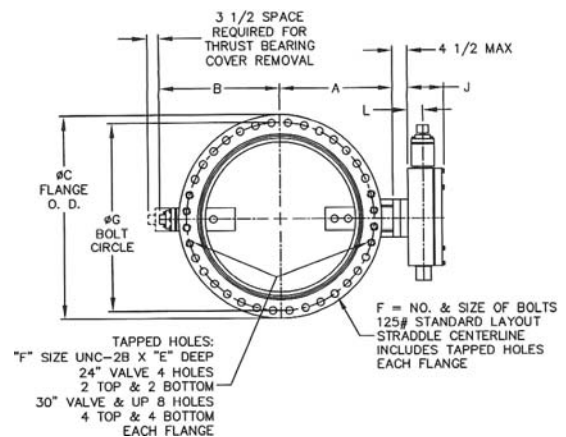
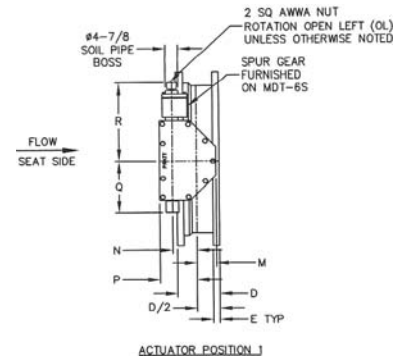

HP250II™ 4"- 20", DUCTILE IRON BODY, MECHANICAL JOINT

| Actuator Size | Valve Size | J | L | M | N | P | Q | R | Number of Turns |
|---------------|------------|---------|---------|-------|--------|--------|-------|---------|-----------------|
| MDT-2S | 3-8" | 4-11/16 | 2 | 2-1/8 | 2 | 4-1/2 | 4-1/2 | 8-1/4 | 32 |
| MDT-3S | 10-14" | 5-5/8 | 2-7/16 | 3-1/4 | 3-5/32 | 5-5/8 | 5-3/8 | 10-3/8 | 30 |
| MDT-4S | 16&18" | 6-3/8 | 2-27/32 | 3-3/8 | 4 | 7-5/16 | 6-3/4 | 11-5/16 | 40 |
| MDT-5 | 20" | 7-9/16 | 3-15/32 | 4-1/2 | 5-1/2 | 8-3/4 | 10 | 17 | 44 |

| Valve Size | A | B | C | D | E | F | G | X |
|------------|--------|--------|----------|--------|--------|--------|--------|-------|
| 4 | 5-1/2 | 3-1/2 | 9 | 8-1/8 | 1 | 4-3/4 | 7-1/2 | 3-1/8 |
| 6 | 6-1/2 | 5-1/8 | 11 | 8-1/2 | 1-1/16 | 6-3/4 | 9-1/2 | 3-1/2 |
| 8 | 7-3/4 | 6-1/2 | 13-1/4 | 8-5/8 | 1-1/8 | 6-3/4 | 11-3/4 | 3-5/8 |
| 10 | 9 | 9-3/4 | 15-9/16 | 9-1/4 | 1-3/16 | 8-3/4 | 14 | 4-1/4 |
| 12 | 10-1/2 | 11-3/8 | 17-15/16 | 9-1/4 | 1-1/4 | 8-3/4 | 16-1/4 | 4-1/4 |
| 14 | 11-7/8 | 12-3/4 | 20-5/16 | 11-1/2 | 1-5/16 | 10-3/4 | 18-3/4 | 4-1/2 |
| 16 | 13-1/2 | 14-1/2 | 22-9/16 | 12 | 1-3/8 | 12-3/4 | 21 | 5 |
| 18 | 14-3/8 | 15-3/8 | 24-11/16 | 12-1/4 | 1-3/8 | 12-3/4 | 23-1/4 | 5-1/4 |
| 20 | 16 | 17 | 27-3/32 | 12-1/2 | 1-1/2 | 14-3/4 | 25-1/2 | 5-1/2 |

NOTES:

- ALL DIMENSIONS SHOWN IN INCHES. "D" DIMENSION $\pm 1/16$ " FOR 3" THRU 10" VALVES. "D" DIMENSION $\pm 1/8$ " FOR 12" THRU 20" VALVES.
- DIMENSIONS AND DRILLING OF MECHANICAL JOINT END CONFORM TO ANSI/AWWA C111/A21.11.
- RECOMMENDATION FOR MATING FLANGES: WHERE INSULATING BUSHINGS ARE USED, IT IS NECESSARY THAT BOLT HOLES BE DRILLED OVERSIZE BY AN AMOUNT EQUAL TO TWO TIMES THE INSULATING SLEEVE THICKNESS TO MAINTAIN THE SAME MINIMUM CLEARANCE FOR BOLTS.
- VALVES MANUFACTURED AND TESTED IN ACCORDANCE WITH AWWA SPECIFICATIONS C504 LATEST REVISION, CLASS 150B.

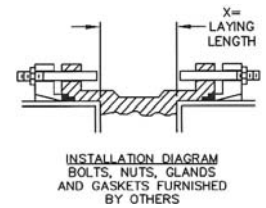
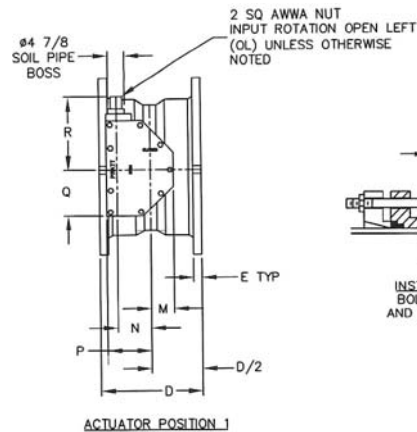
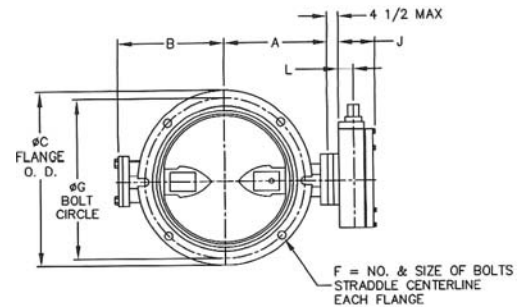

HP250II™ 24"- 48", DUCTILE IRON BODY, MECHANICAL JOINT

| Valve Size | A | B | C | D | E | F | G | X |
|------------|---------|--------|---------|--------|---------|----------|--------|-------|
| 24 | 18-5/8 | 18-5/8 | 31-9/16 | 13-1/4 | 1-5/8 | 16-3/4 | 30 | 6-3/8 |
| 30 | 21-1/2 | 24-3/8 | 39 | 18 | 1-13/16 | 20-1 | 36-7/8 | 10 |
| 36 | 25-7/16 | 28-1/4 | 45-7/8 | 22 | 2 | 24-1 | 43-3/4 | 14 |
| 42 | 29-7/8 | 32-7/8 | 53 | 22 | 2 | 28-1-1/4 | 50-5/8 | 14 |
| 48 | 34-1/16 | 37-1/8 | 59-7/8 | 24 | 2 | 32-1-1/4 | 57-1/2 | 16 |

| Actuator Size | J | L | M | N | P | Q | R | Number of Turns |
|---------------|--------|---------|-------|-------|--------|----------|---------|-----------------|
| MDT-4S | 6-3/8 | 3-7/16 | 3-3/8 | 4 | 7-5/16 | 6-3/4 | 11-5/16 | 40 |
| MDT-5 | 7-9/16 | 3-1/2 | 4-1/2 | 5-1/2 | 8-3/4 | 10-7/16 | 17 | 44 |
| MDT-5S | 8-5/16 | 3-15/16 | 5-5/8 | 7 | 10-5/8 | 15-15/16 | 19-7/8 | 136 |
| MDT-6S | 9-7/8 | 5-1/16 | 7 | 8-1/4 | 12-5/8 | 18-5/8 | 26-1/2 | 215 |

NOTES:

- ALL DIMENSIONS SHOWN IN INCHES. "D" DIMENSION $\pm 1/8$ ". BOLT HOLES WILL BE 1/8" LARGER THAN DIAMETER OF BOLT.
- DIMENSIONS AND DRILLING OF MECHANICAL JOINT ENDS CONFORM TO ANSI/AWWA C111/A21.11.
- CAUTION: IT IS RECOMMENDED THAT VALVES BE INSTALLED INTO PIPING SYSTEM IN ACCORDANCE WITH AWWA M-11 TO PREVENT ANY UNDESIRABLE PIPING STRESS, DEFLECTION OR BENDING THAT MAY AFFECT THE PERFORMANCE OF THE VALVE.

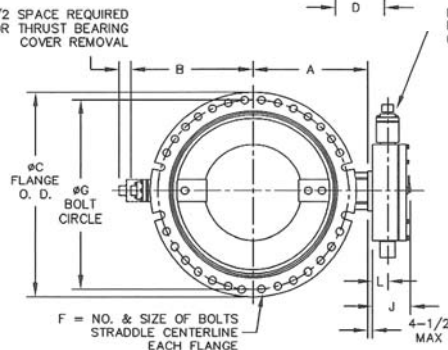
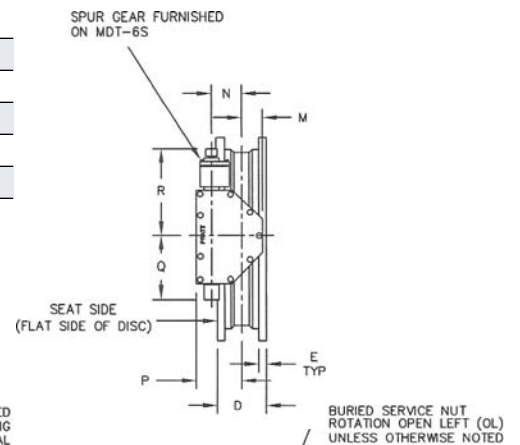

SCOPE OF THE LINE: PRATT HP250™ BUTTERFLY VALVE



Sizes: 4" through 48"

Body Style:

- Flanged, 250#

Pressure Class:

- AWWA 250 B

Actuation Options*:

- Nut
- Handwheel
- Buried Service

*Consult factory for other end connections and actuation options

HP250™ BUTTERFLY VALVE, 250# FLANGED ENDS SPECIFICATION

HP250™ Butterfly Valve

Class 250 For Buried Service

Valves shall be manufactured with a 250 psi rating. The valves shall be capable of operating at pressures of 250 psi and will comply with the following details:

Valve Bodies shall be constructed of ductile iron ASTM A-536. End connections shall be ANSI Class 250 with 250# drilling pattern.

Valve Discs shall be made from ductile iron ASTM A-536. Discs shall be furnished with 316 stainless steel seating edge to mate with the rubber seat.

Valve Seat shall be Buna-N rubber located on the valve body.

Valve Shafts shall be stainless steel ASTM A-564 Type 630 Condition H-1150. Stub shafts or through shafts are acceptable.

Shaft Seals shall be standard self-adjusting split "V" type packing. Shaft seals shall be of a design allowing replacement without removing the valve shaft.

Valve Bearings

Valve bearings shall be sleeve type that are corrosion resistant and self-lubricating.

Valve Actuators

Valve actuators shall be fully grease packed and have stops in the open/closed position. The actuator shall have a mechanical stop which will withstand an input torque of 450 ft/lbs. against the stop. The traveling nut shall engage alignment grooves in the housing. The actuators shall have a built in packing leak bypass to eliminate possible leakage into the actuator housing.

Valve Interior and Exterior Surfaces except for seating shall be coated with two coats of epoxy paint in accordance with TT-C-494A and AWWA C504 latest edition.

All Valves shall be hydrostatic and leak tested. The leak test shall be performed at a differential pressure of 250 psi with the disc in a closed position. In a slightly open position, internal hydrostatic pressure equal to 500 psi shall be applied to the inside of the valve body for five minutes.

HP250™ 4"-48", CAST OR DUCTILE IRON, ANSI 250# FLANGED, 250# DRILL

| Actuator Size | J | L | M | N | P | Q | R | Number of Turns |
|---------------|---------|---------|-------|--------|--------|----------|---------|-----------------|
| MDT-2S | 4-11/16 | 2 | 2-1/8 | 2 | 4-1/2 | 4-1/2 | 8-1/4 | 32 |
| MDT-3S | 5-5/8 | 2-7/16 | 3-1/4 | 3-5/32 | 5-5/8 | 5-3/8 | 10-3/8 | 30 |
| MDT-4S | 6-3/8 | 2-27/32 | 3-3/8 | 4 | 7-5/16 | 6-3/4 | 11-5/16 | 40 |
| MDT-5 | 7-9/16 | 3-15/32 | 4-1/2 | 5-1/2 | 8-3/4 | 10 | 17 | 44 |
| MDT-5S | 8-5/16 | 3-15/16 | 5-1/2 | 7 | 10-1/2 | 15-15/16 | 19-7/8 | 136 |
| MDT-6S | 10-3/16 | 5-1/16 | 7 | 8-1/4 | 12-5/8 | 14-3/16 | 26-1/2 | 215 |

| Valve Size | A | B | C | D | E | F | G |
|------------|--------|--------|--------|----|---------|----------|--------|
| 4 | 5-1/2 | 3-1/2 | 10 | 5 | 1-1/4 | 8-3/4 | 7-7/8 |
| 6 | 7-1/4 | 8-3/8 | 12-1/2 | 6 | 1-7/16 | 12-3/4 | 10-5/8 |
| 8 | 8-1/2 | 9-5/8 | 15 | 8 | 1-5/8 | 12-7/8 | 13 |
| 10 | 9-3/4 | 11 | 17-1/2 | 8 | 1-7/8 | 16-1 | 15-1/4 |
| 12 | 11-1/2 | 12-5/8 | 20-1/2 | 8 | 2 | 16-1-1/8 | 17-3/4 |
| 14 | 12-3/4 | 13-7/8 | 23 | 12 | 2-1/8 | 20-1-1/8 | 20-1/4 |
| 16 | 14 | 15-1/8 | 25-1/2 | 12 | 2-1/4 | 20-1-1/4 | 22-1/2 |
| 18 | 15-1/4 | 16-3/8 | 28 | 12 | 2-3/8 | 24-1-1/4 | 23-3/4 |
| 20 | 17 | 17-5/8 | 30-1/2 | 12 | 2-1/2 | 24-1-1/4 | 27 |
| 24 | 19-3/4 | 20-1/4 | 36 | 12 | 2-3/4 | 24-1-1/2 | 32 |
| 30 | 25-5/8 | 26 | 43 | 12 | 3 | 21-1-3/4 | 39-1/4 |
| 36 | 28-1/8 | 31-1/8 | 50 | 15 | 3-3/8 | 32-2 | 46 |
| 42 | 32-1/8 | 35-1/8 | 57 | 15 | 3-11/16 | 36-2 | 52-3/4 |
| 48 | 36-1/4 | 39-5/8 | 65 | 15 | 4 | 40-2 | 60-3/4 |

NOTES:

1. ALL DIMENSIONS SHOWN IN INCHES.
2. "D" DIMENSION ±1/8"
3. FOR BOLTS SMALLER THAN 01-3/4, BOLT HOLES WILL BE 1/8" LARGER THAN DIAMETER OF BOLT. FOR BOLTS 01-3/4 OR LARGER, BOLT HOLES WILL BE 1/4" LARGER THAN DIAMETER OF BOLT.
4. DIMENSIONS AND DRILLING OF END FLANGES CONFORM TO THE AMERICAN CAST IRON FLANGE STANDARDS, CLASS 125 (B16.1).
5. RECOMMENDATION FOR MATING FLANGES: WHERE INSULATING BUSHINGS ARE USED, IT IS NECESSARY THAT BOLT HOLES BE DRILLED OVERSIZE BY AN AMOUNT EQUAL TO TWO TIMES THE INSULATING SLEEVE THICKNESS TO MAINTAIN THE SAME MINIMUM CLEARANCE FOR BOLTS.
6. CAUTION: IT IS RECOMMENDED THAT VALVES BE INSTALLED INTO PIPING SYSTEM IN ACCORDANCE WITH AWWA M-11 TO PREVENT ANY UNDUE PIPING STRESS, DEFLECTION OR BENDING THAT MAY EFFECT THE PERFORMANCE OF THE VALVE.
7. EXTENSION STEM CAN BE USED WITH STANDARD VALVE BOXES OR 5" SOIL PIPE.

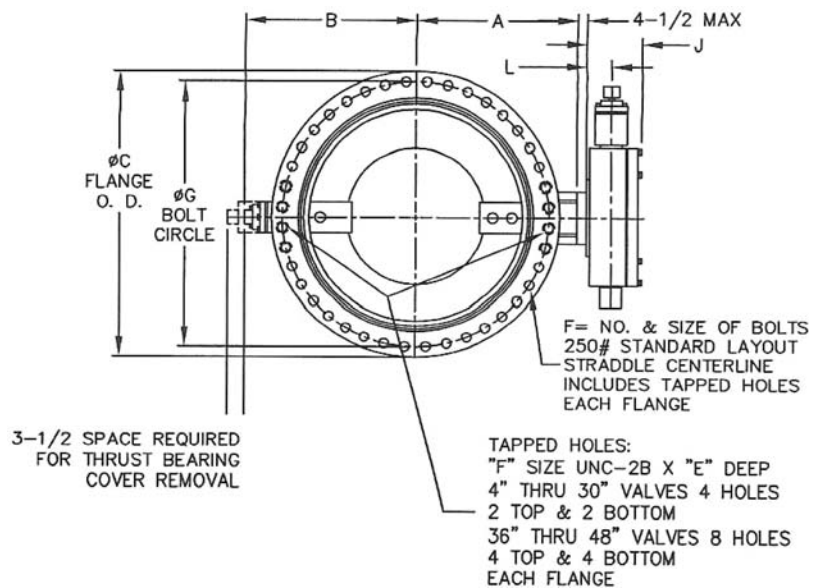
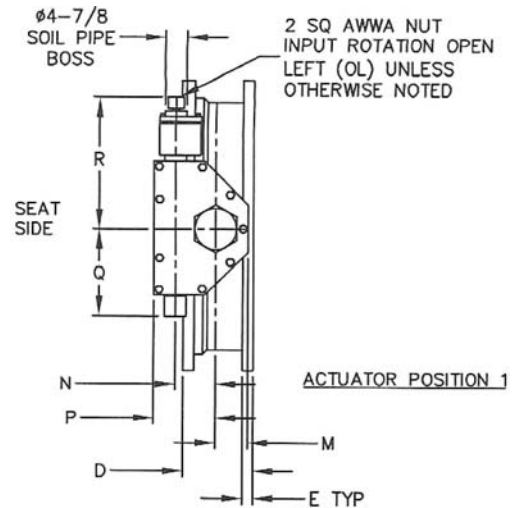

Pratt History >

Engineering >

Products >

Specifications >

<http://www.henrypratt.com/>

PRATT PRODUCT GUIDE

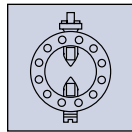

Model 2FI

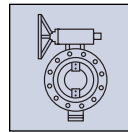

Triton® HP250

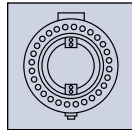

Triton® XR70



Control Systems

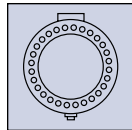

Triton® XL

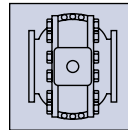

Metal Seated Ball Valve

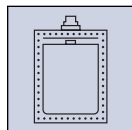

Rectangular

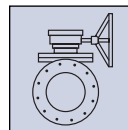

Plug Valve

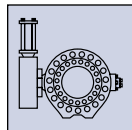

Rubber Seated Ball Valve

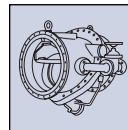

Tilting Disc Check Valve

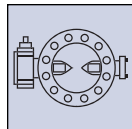

Groundhog® Valve

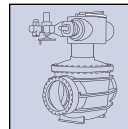

Cone Valve

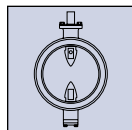

Monoflange MKII

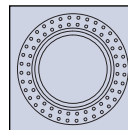

Sleeve Valve

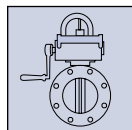

Indicating Butterfly Valve
UL & FM approved

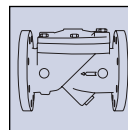

Check Valve

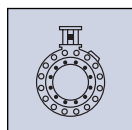

N-Stamp Nuclear Butterfly Valve

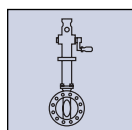

PIVA Post Indicating Valve Assembly
UL & FM approved



Henry Pratt Company

401 South Highland Avenue
Aurora, Illinois 60506-5563
Toll Free 877-436-7977
Phone 630-844-4000
Fax 630-844-4160
www.henrypratt.com
ISO 9001: 2000 Certified

©2007 Henry Pratt Company
Printed in the U.S.A.
HP250-0507

