

Rubber Seated Ball Valve



Operation and Maintenance Manual

Job Name: _____

Contractor: _____

Date: _____

Rubber Seated Ball Valve

SAFETY MESSAGES

All safety messages in the instructions are flagged with an exclamation symbol and the word “Warning”. These messages indicate procedures that must be followed exactly to avoid equipment damage, physical injury, or death. Safety labels on the product indicate hazards that can cause equipment damage, physical injury, or death.



WARNING

Personnel involved in the installation or maintenance of valves should be constantly alert to potential emission of pipeline material and take appropriate safety precautions. Always wear suitable protection when dealing with hazardous pipeline materials.

PARTS

Order parts from your local Henry Pratt sales representative or directly from Henry Pratt Company. When ordering parts, please include the serial number located on the valve tag.

WARRANTY ISSUE

Seller warrants that, at its option, it will repair, replace, or refund the unit purchase price of any products which are non-conforming due to Seller’s material or workmanship during the warranty period. The warranty period shall be twelve (12) months for parts and eighteen (18) months for all other goods after date of shipment. This shall be Buyer’s sole remedy. In order to maintain this product warranty, Buyer must give written notice to Seller’s Field Service Supervisor prior to any work being performed.

IN CONSIDERATION OF THE FOREGOING, SELLER EXCLUDES ALL OTHER EXPRESS OR IMPLIED WARRANTIES, INCLUDING BUT NOT LIMITED TO MERCHANTABILITY AND FITNESS FOR A PARTICULAR PURPOSE.

Seller does not warrant water operated metallic cylinders against damage caused by corrosion, electrolysis or mineral deposits. In no event shall warranty include valve removal or reinstallation.



WARNING

Read all applicable directions and instructions prior to any maintenance, troubleshooting or installation

Table of Contents

FUNCTIONAL DESCRIPTION	4
INSTALLATION	5
OPERATION	6
MAINTENANCE	6
TROUBLESHOOTING	7
CONTACTING PRATT	8
PRODUCT DRAWINGS	9

Rubber Seated Ball Valve

FUNCTIONAL DESCRIPTION

Ball valve rotors rotate 1/4 turns to provide tight shutoff in air or water pipelines. The valves can be used to regulate flow rate or pressure by positioning the rotor between 15 and 90 degrees open.

Manually operated ball valves are powered with gear actuators, which convert multiple handwheel, chainwheel or nut input turns into 1/4 turn valve operation. The travel of the valve rotor is limited by physical stops in the actuator housing.



WARNING

Forcing the handwheel, chainwheel or nut against the stops will not provide tighter shutoff of the valve and may damage the actuator. Only actuator adjustments will affect valve shutoff.

Motor operated ball valves are powered with gear actuators, which convert multiple motor input turns into 1/4 turn valve operation. The travel of the valve rotor is limited by limit switches in the motor housing and physical stops in the actuator housing. Valve shutoff is affected by limit switch and physical stop settings.



WARNING

Improperly set limit switches and/or physical stops may damage the motor and/or actuator.

Hydraulically operated ball valves are powered with a gear box and double acting cylinder. The linear stroke of the cylinder is converted to 1/4 turn operation by the gear box. Auxiliary controls are provided to direct hydraulic power to the cylinder and to control the operating speed of the cylinder.

Rubber Seated Ball Valve

INSTALLATION

Installation of your ball valve should be accomplished by personnel well versed in piping installation and who are familiar with the end configuration used to join the components. The use of standard, good joining procedures are all that are normally required. The only notable precaution would be in regard to the direction of the fluid flow. In the case of the single seated valve, the seat must be oriented toward the down stream side of the valve.

Refer to the mechanical general arrangement drawings prepared for this specific valve during installation. The flow direction and actuator orientation are given on the drawing. The valve should be installed with the rotor in the closed or near closed position to prevent damage to the seating edge when lowered into the pipeline. Wrap the lifting sling around the base of the horizontal axis trunnions to lift the valve. Alternatively, bars or lifting eyes can be inserted through the flange holes for lifting. The valve should be bolted to the pipe with a rubber ring gasket suitable for the pipeline fluid and pressure.



WARNING

Do not remove the actuator with water in the pipe, or the valve may suddenly open and cause physical damage or personal injury.



WARNING

Persons who will install, operate or adjust this equipment must read the instructions and drawings carefully. Injury and property damage may occur from improper use. It is understood that this equipment will be installed by individuals with knowledge and skills in the equipment.



WARNING

Do not lift the valve by the actuator. The actuator and actuator bolting can not support the weight of the valve.

Rubber Seated Ball Valve

OPERATION

Flow control is achieved by rotating the rotor inside of the pipe line about its diametrical axis, hence changing the total free flow area of the valve. At full closed, a leak tight seal is achieved by the rotor mechanically compressing the rubber seat causing a seal between the rotor and the seat.

Positioning of the rotor is achieved by the valve actuator which has been mounted, adjusted, and tested at our Plant. Your valve may be motor, cylinder, or manually operated. Operation and maintenance of your specific type of actuator is discussed in another section of this manual.

The manually operated ball valves should be fully cycled from close to open and back to the closed position to verify operation. Do not force the valve in the closed position if tight shutoff is not achieved; make adjustments to the operator per the maintenance instructions.

For ball valves equipped with power cylinder actuators, connect the specified hydraulic pressure to the cylinder and controls. All hydraulic supplies must be filtered to prevent contamination and clogging of the controls. The valve can be cycled open and closed by powering the solenoid valves mounted on the cylinder.

MAINTENANCE

Although the actuator may or may not require periodic maintenance (depending upon which actuator is used), the valve itself requires no periodic maintenance. Pratt rubber seat valves are supplied with self-lubricating teflon lined fiberglass back sleeve bearings. No maintenance attention to them is necessary.

However, after many years of continued service, the rubber components of your Pratt Ball Valve may show signs of wear. These parts are the valve stem packing and the rubber seat which are the only field replaceable components of your rubber seated Ball Valve. We do not recommend stocking spare seats. The seat and packing are designed for years of service. If repair or replacement of these parts becomes apparent (by leaking), please contact the Pratt's Parts Department who can provide estimates for parts and field service work.

Rubber Seated Ball Valve

TROUBLESHOOTING

PROBLEM	CAUSES	REMEDIES
Leakage between valve and actuator	<ul style="list-style-type: none"> • Packing Leak 	<ul style="list-style-type: none"> • Clean packing bore and replace packing
Bottom trunnion leaks	<ul style="list-style-type: none"> • O-ring or gasket leak 	<ul style="list-style-type: none"> • Replace bottom O-ring or gasket
Valve leaks when closed	<ul style="list-style-type: none"> • Rotor not fully closed or past fully closed • Rotor edge wear or damage • Body rubber seat wear or damage • Loose debris in valve 	<ul style="list-style-type: none"> • Adjust actuator closed position stop • Clean and/or repair rotor edge • Adjust or replace valve seat • Cycle valve five times to flush out debris
Chain wheel jams	<ul style="list-style-type: none"> • Poorly fitting chain 	<ul style="list-style-type: none"> • Replace with correct chain
Valve hard to operate	<ul style="list-style-type: none"> • Foreign material in valve • Corroded actuator parts • Loose actuator 	<ul style="list-style-type: none"> • Remove obstructions • Clean and grease actuator • Apply loctite or Omni-fit locking compound and tighten bolts
Automatic valve does not actuate	<ul style="list-style-type: none"> • No power source • Improper signal • Burned out or impaired component 	<ul style="list-style-type: none"> • Check incoming power source and replace fuses or reset pressure • Check actuating signal sequence • Check and repair or replace solenoids, motors and relay devices.



Rubber Seated Ball Valve

HOW TO CONTACT PRATT

HOW TO ORDER PARTS:

To order parts, contact our Parts Department:

Write: - Henry Pratt Company
401 South Highland Avenue
Aurora, IL 60506-5563

Attn: Parts Manager

Call - (630) 844-4000

Fax - (630) 844-4191

Please include valve serial number and description of part requested.

HOW TO OBTAIN SERVICE:

To obtain further information or secure field service, contact our Field Service Department:

Write: - Henry Pratt Company
401 South Highland Avenue
Aurora, IL 60506-5563

Attn: Field Service Manager

Call - (630) 844-4163

Fax - (630) 844-4160

Please include the following with your inquiry for service:

Henry Pratt Order Number:
Henry Pratt Item Number:
Valve Serial Number:
Type of Service Requested

Rubber Seated Ball Valve

Pratt Single Seat Rubber Seated Ball Valve Parts Drawing

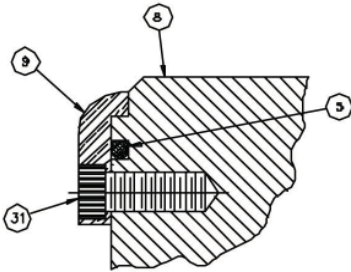

SEAT DETAIL
6", 8", AND 10"
BALL VALVES ONLY

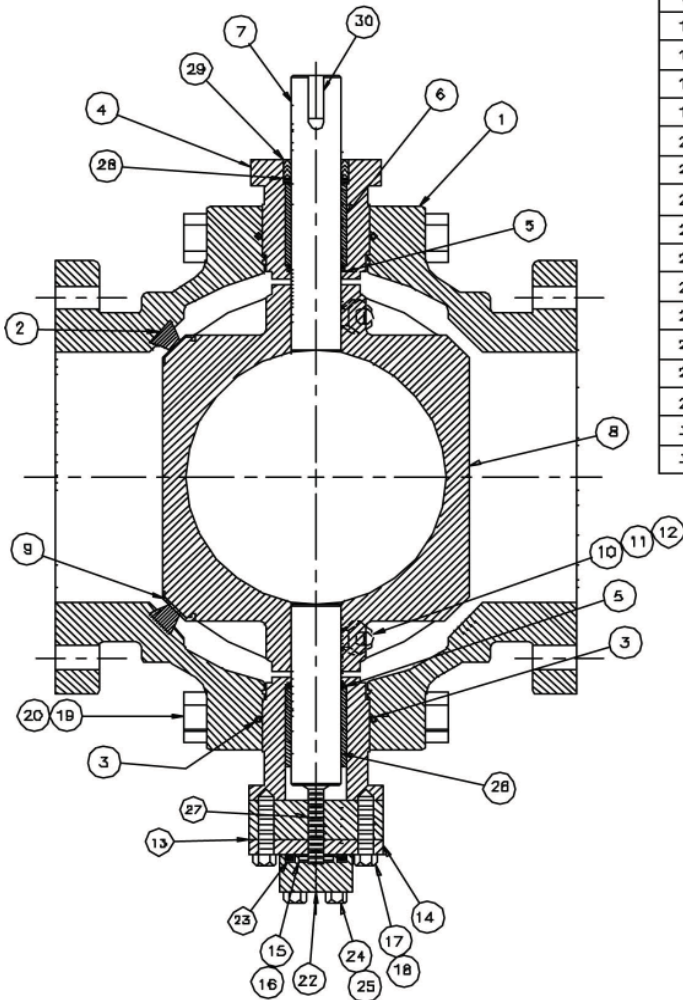

ITEM NO.	DESCRIPTION	MATERIALS
1	END PIECE	CAST IRON ASTM A-126 CLASS B
2	RUBBER SEAT	RUBBER BJNA-N
3	O-RING	RUBBER BJNA-N
4	CENTERPIECE	CAST IRON ASTM A-126 CLASS B
5	O-RING	RUBBER BJNA-N
6	BEARINGS	DUROLON
7	TOP STUB SHAFT	STAINLESS STEEL ASTM A-276 TYPE 304
8	ROTOR	CAST IRON ASTM A-48 CLASS 40
9	ROTOR EDGE	STAINLESS STEEL ASTM A-240 TYPE 316
10	TAPER PINS	STAINLESS STEEL ASTM A-276 TYPE 304
11	LOCKWASHERS	STAINLESS STEEL 18-8 TYPE 304
12	HEX NUTS	STAINLESS STEEL 18-8 TYPE 304
13	BOTTOM COVER GASKET	NON ASBESTOS MATERIAL ASTM F104
14	BOTTOM COVER	CAST IRON ASTM A-126 CLASS B
15	THRUST COLLAR	BRONZE BAR ASTM B-505 ALLOY C-93200
16	GROOVE PIN	ALLOY STEEL
17	CAP SCREWS	CARBON STEEL SAE GRADE 2 (ZINC PLATED)
18	LOCTITE	GRADE CV
19	STUD	CARBON STEEL AISI B12L14
20	HEX NUT	CARBON STEEL SAE GRADE 2 (ZINC PLATED)
21	LOCTITE	GRADE CV
22	BOTTOM COVER CAP	CAST IRON ASTM A-126 CLASS B
23	O-RING	RUBBER BJNA-N
24	CAP SCREW	CARBON STEEL SAE GRADE 2 (ZINC PLATED)
25	LOCTITE	GRADE CV
26	BOTTOM STUB SHAFT	STAINLESS STEEL ASTM A-276 TYPE 304
27	THRUST BEARING STUD	STAINLESS STEEL TYPE 304
28	BOTTOM PKG RTNR	NYLON 101
29	PACKING	RUBBER BJNA-N
30	KEY	AISI C1045 COLD DRAWN STEEL
31	CAP SCREW	STAINLESS STEEL TYPE 304

Rubber Seated Ball Valve

Pratt Double Seat Rubber Seated Ball Valve Parts Drawing

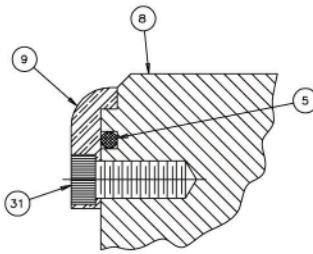

SEAT DETAIL
6" 8" AND 10"
BALL VALVES ONLY

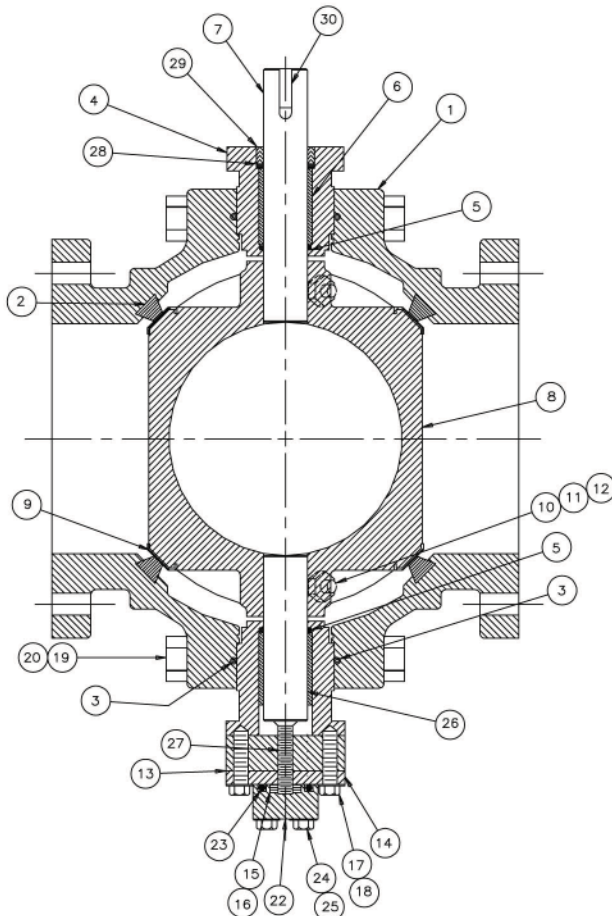

ITEM NO.	DESCRIPTION	MATERIALS
1	END PIECE	DUCTILE IRON ASTM A-536 (65-45-12) CAST IRON ASTM A-126 CLASS B
2	RUBBER SEAT	RUBBER BUNA-N
3	O-RING	RUBBER BUNA-N
4	CENTERPIECE	DUCTILE IRON ASTM A-536 (65-45-12) CAST IRON ASTM A-126 CLASS B
5	O-RING	RUBBER BUNA-N
6	BEARINGS	DURALON
7	TOP STUB SHAFT	STAINLESS STEEL ASTM A-276 TYPE 304 STAINLESS STEEL ASTM A-276 TYPE 316 STAINLESS STEEL ASTM A-564 TYPE 630 17-4 PH COND. H-1150
8	ROTOR	CAST IRON ASTM A-48 CLASS 40 DUCTILE IRON ASTM A-536 (65-45-12)
9	ROTOR EDGE	STAINLESS STEEL ASTM A-240 TYPE 316
10	TAPER PINS	STAINLESS STEEL ASTM A-276 TYPE 304 STAINLESS STEEL ASTM A-276 TYPE 316 STAINLESS STEEL ASTM A-564 TYPE 630 17-4 PH COND. H-1150
11	LOCKWASHERS	STAINLESS STEEL TYPE 304
12	HEX NUTS	STAINLESS STEEL TYPE 304
13	BOTTOM COVER GASKET	NON ASBESTOS MATERIAL ASTM F104
14	BOTTOM COVER	CAST IRON ASTM A-126 CLASS B DUCTILE IRON ASTM A-536 (65-45-12)
15	THRUST COLLAR	BRONZE BAR ASTM B-505 ALLOY C-93200
16	GROOVE PIN	ALLOY STEEL
17	CAP SCREW	CARBON STEEL SAE GRADE 2 (ZINC PLATED) STAINLESS STEEL TYPE 304 STAINLESS STEEL TYPE 316
18	LOCTITE	GRADE CV
19	STUD	CARBON STEEL AISI B12L14
20	HEX NUT	CARBON STEEL SAE GRADE 2 (ZINC PLATED)
21	LOCTITE	GRADE CV
22	BOTTOM COVER CAP	CAST IRON ASTM A-126 CLASS B DUCTILE IRON ASTM A-536 (65-45-12)
23	O-RING	RUBBER BUNA-N
24	CAP SCREW	CARBON STEEL SAE GRADE 2 (ZINC PLATED) STAINLESS STEEL TYPE 304 STAINLESS STEEL TYPE 316
25	LOCTITE	GRADE CV
26	BOTTOM STUB SHAFT	STAINLESS STEEL ASTM A-276 TYPE 304 STAINLESS STEEL ASTM A-276 TYPE 316 STAINLESS STEEL ASTM A-564 TYPE 630 17-4 PH COND. H-1150
27	THRUST BEARING STUD	STAINLESS STEEL TYPE 304
28	BOTTOM PKG RTNR	NYLON 101
29	PACKING	RUBBER BUNA-N
30	KEY	AISI C1045 COLD DRAWN STEEL
31	CAP SCREW	STAINLESS STEEL TYPE 304