

PRATT®

a **MUELLER** brand

OPERATION/MAINTENANCE MANUAL

Diviner Position Indicator

TABLE OF CONTENTS	PAGE
General Information	2
Installation /Operation /Maintenance	3
Parts Information	4



WARNING:

1. Read all applicable directions and instructions prior to any maintenance, troubleshooting or installation.
2. Personnel involved in the installation or maintenance of valves should be constantly alert to potential emission of pipeline material and take appropriate safety precautions. Always wear suitable protection when dealing with hazardous pipeline materials.
3. Order parts from your local Pratt sales representative or directly from Pratt. When ordering parts, please include the serial number located on the valve tag.

NOTE: "WARNING" and "CAUTION" messages (flagged with an exclamation symbol) indicate procedures that must be followed exactly to avoid equipment damage, physical injury, or death.

F 13804 11/18

MUELLER

FUNCTIONAL DESCRIPTION

The Pratt® Diviner is a valve position indicator used for buried valves to enable you to identify valve position, identification, and operating directions at a glance. It is installed in a standard 5 1/4" buried valve box just below the removable valve box cover. The Pratt Diviner is adjustable for use with valves requiring 0 - 100 or 0 - 250 turns. The working parts are made from a durable, non-metallic material that provides maintenance-free operation in buried valve service.

The Diviner Position Indicator is shipped for field assembly complete with the following:

1. Cast Iron Adapter
2. Caps Screws & Guide Bushing
3. Position Indicator
4. Flexible Washer
5. 2" Square AWWA Nut with Set Screw
6. Standard 5 1/4" Valve Box*
7. 5" Cast Iron Soil Pipe Bell* utilizing a Cast Cover with skirt depth of 1" or less
8. Extension Stems**

*Furnished by others

**Supplied in 5' or 10' lengths and can be ordered separately at extra cost.

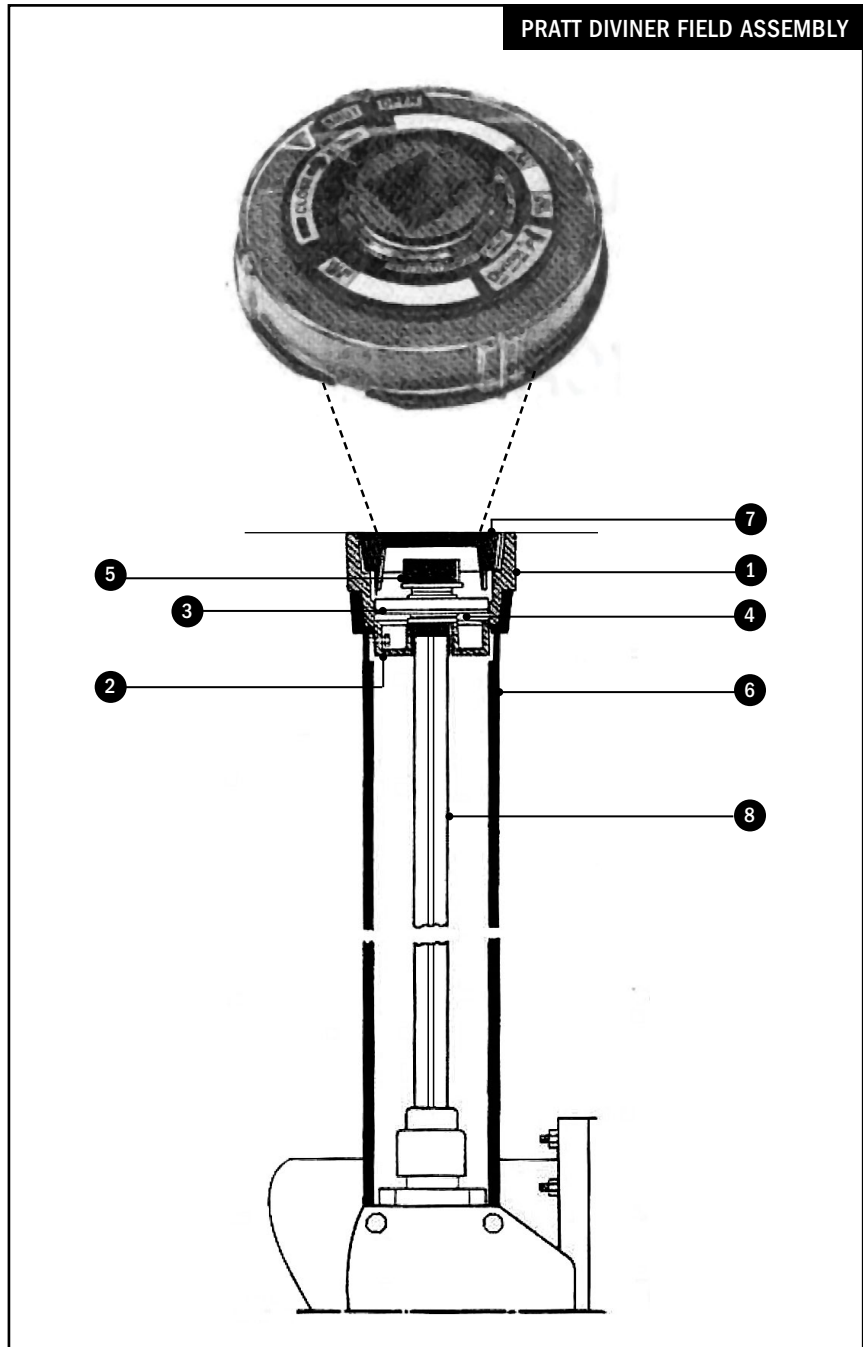

INSTALLATION / OPERATION

The following procedure should be followed for ease of installation.

- 1.** Establish desired finished elevation and adjust the existing valve box to 3" below this elevation.
- 2.** Assemble extension stem by inserting extension shaft to the drive collar and securing by means of set screws.
- 3.** Assemble extension stem assembly to operator by placing the drive collar over the AWWA nut on the operator, taking care that the drive collar is properly seated.
- 4.** Measure 1 3/4" up from the top of the adjusted valve box and mark extension shaft at this point. Cut off excess shaft. De-burr.
- 5.** Place indicator adapter inside the valve box and tighten hex head cap screws so that the adapter will not rotate in the valve box.
- 6.** Slip guide bushing over extension shaft and seat in indicator adapter. A light coat of grease may be applied to the mating surfaces of these two parts.
- 7.** Adjust the Diviner indicator for the intended valve as follows:
 - a) The transparent top cover of the Diviner must be clean and free of any oil or dirt. Clean with Methyl Alcohol only. DO NOT use grease solvents of any kind or the transparency may be destroyed. Allow to dry before proceeding.

- b) Position the base plate (the decal having the numbers from 0 to 102/255) on the Diviner face. While holding the decal at the top half, raise the bottom half and remove the paper backing and anchor decal to Diviner. Then remove the backing from the top half. DO NOT remove all the backing at one time or it will be difficult to position the decal properly. Remove any trapped air bubbles.
- c) Use the table below for Pratt® valves with Pratt MDT Actuators.

VALVE SIZE	ACTUATOR	NO. OF TURNS
3" - 12"	MDT-2S	32
14" - 16"	MDT-3S	30
16" - 24"	MDT-4S	40
24" - 36"	MDT-5	44
36" - 48"	MDT-5S	136
42" - 72"	MDT-6S	215

- d) Position the top plate (the decal with the "Divinewwwwr" logo) so that the window is lined up with the appropriate number of turns. Repeat the procedure described for the base plate.
- e) If using an actuator other than an MDT, turn the nut on the actuator until the valve is fully closed. Next, open the valve and count the number of turns required to bring the valve to the full open position.

Close the valve and again count the number of turns required to fully close the valve. The number of turns to close the valve should equal the number of turns to open the valve. Record the number of turns required to open and close the valve.

⚠ CAUTION: Be sure the plates are properly positioned before removing the backing paper. The adhesive is strong, making it extremely difficult to reposition after being glued down.

- 8.** Determine whether the valve is in the open or closed position and set the position indicator (Diviner) accordingly.
- 9.** Slip position indicator over the extension shaft and lower into correct position in the indicator taking care that the flat portions of the indicator flange match up with the flat keys in the indicator adapter.
- 10.** Slip the felt washer over the end of the extension shaft and on to the indicator hub.
- 11.** Assemble 2" square nut to extension shaft and press down firmly while tightening set screws.
- 12.** Replace existing valve box cover.
- 13.** To disassemble reverse the above procedure.

MAINTENANCE

The "Diviner" position indicator is a sealed, water-tight unit and is not intended for field maintenance. No attempt should be made to

disassemble. Additional decals are available if the Diviner is transferred to another valve installation.

DIVINER POSITION INDICATOR

Parts Information

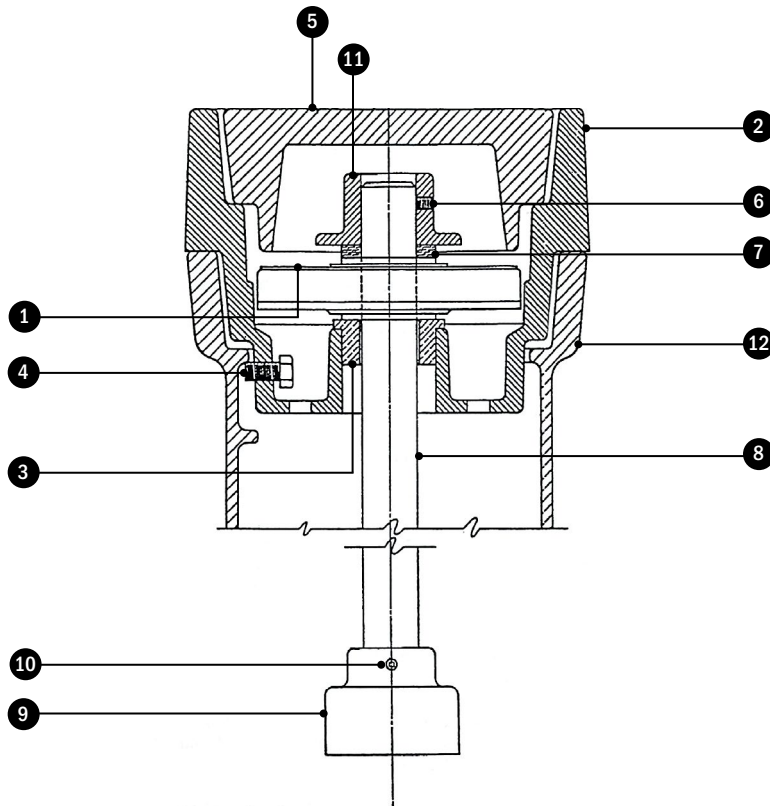

PARTS LIST

ID	DESCRIPTION
1	Diviner
2	Indicator Adapter
3	Guide Bushing
4	Hex Head Cap Screw
5	2" Square Nut
6	Set Screw
7	Felt Washer
8	Extension Shaft*
9	Drive Collar
10	Input Shaft Set Screw
11	Valve Box Cover**
12	Valve Box**

*Available in 5' and 10' lengths

**To be supplied by others

TO ORDER: Contact our Parts Department.

Pratt

401 South Highland Avenue

Aurora, IL 60506-5563

Attn: Parts Manager

630.844.4000

When ordering parts, please include the serial number located on the valve tag and description of part requested.

MUELLER® | ECHOLOGICS® | HYDRO GATE® | HYDRO-GUARD® | JONES® | MI.NET® | MILLIKEN® | PRATT® | SINGER® | U.S. PIPE VALVE & HYDRANT

1.800.423.1323 - www.prattvalve.com - moreinfo@muellercompany.com

INTERNATIONAL - 1.423.490.9555 - www.mueller-international.com - international@muellercompany.com

Mueller refers to one or more of Mueller Water Products, Inc., a Delaware corporation ("MWP"), and its subsidiaries. MWP and each of its subsidiaries are legally separate and independent entities when providing products and services. MWP does not provide products or services to third parties. MWP and each of its subsidiaries are liable only for their own acts and omissions and not those of each other. MWP brands include Mueller®, Echologics®, Hydro Gate®, Hydro-Guard®, Jones®, Mi.Net®, Milliken®, Pratt®, Singer®, and U.S. Pipe Valve & Hydrant. Please see www.muellerwp.com/about to learn more.



Copyright © 2018 Henry Pratt Company, LLC. All Rights Reserved. The trademarks, logos and service marks displayed in this document are the property of Mueller Water Products, Inc., its affiliates or other third parties. Products above marked with a section symbol (§) are subject to patents or patent applications. For details, visit www.mwppat.com. These products are intended for use in potable water applications. Please contact your Mueller Sales or Customer Service Representative concerning any other application(s).