

# PRATT®

a **MUELLER** brand

OPERATION/MAINTENANCE MANUAL

# 740G Double Disc Check Valve

TABLE OF CONTENTS	PAGE
General Information	2
Installation / Operation	3
Troubleshooting / Assembly	4
Parts Information	5



## WARNING:

1. Read all applicable directions and instructions prior to any maintenance, troubleshooting or installation.
2. Personnel involved in the installation or maintenance of valves should be constantly alert to potential emission of pipeline material and take appropriate safety precautions. Always wear suitable protection when dealing with hazardous pipeline materials.
3. Order parts from your local Pratt sales representative or directly from Pratt. When ordering parts, please include the serial number located on the valve tag.

*NOTE: "WARNING" and "CAUTION" messages (flagged with an exclamation symbol) indicate procedures that must be followed exactly to avoid equipment damage, physical injury, or death.*

F 13808 11/18

**MUELLER**

### OVERVIEW

The double disc check valve is built with stainless trim to give years of trouble-free operation. The double disc check valve can be installed in either horizontal or vertical pipelines that carry clean water or air. This valve is not intended to carry fluids containing solids such as raw sewage or wastewater, nor is it suited for fluids that contain hazardous gases.

The double disc check valve is designed to provide flow in the direction of the arrow marked on the outside nameplate, and instantaneously close upon sensing flow reversal. The nameplate will also indicate valve size, model number, working pressure and materials of construction.

### Valve Construction

The standard double disc check valve body is made from ductile iron. The balance of the internal wetted components are made from type 304 stainless steel. The disc and spring are the only moving parts and require no lubrication or maintenance.

The body is a compact wafer type that fits between two pipe flanges. The EPDM seat is bonded to the body and if damaged is not field repairable.

### Receiving and Storage

When valves arrive on site they should be inspected for any shipping damage. Valves should be off loaded from their carrier without being dumped or dropped. When lifting the valve use lifting straps around the body and never lift a valve with straps or chains through the body.

Valves should remain in their original shipping container until ready to install into the pipeline. This will prevent any weather related damage to occur and void the warranty. For extended periods of storage the container should remain closed so to not expose the valves seat materials to direct sunlight or ozone.

### Maintenance-Free

The double disc check valve is lubrication and maintenance free. Once the double disc check valve is installed correctly it will provide the end user many years of trouble free service.



### INSTALLATION

The double disc check valve is installed in the pipeline between two flanges. The flow arrow that is stamped on the nameplate must point in the direction of fluid flow when the pump is running or when the system is in operation. The valve can be installed either horizontally or vertically, with the flow up. For ease of future reference install the valve with the nameplate in the visible orientation.

The valve will be installed between two flanges in accordance with ANSI B16.1, Cl. 125, ANSI B16.5 Cl. 150

or AWWA C207, Cl. D or E. When mating the double disc check valve with isolation valves, the downstream isolation valve must be at least one pipe diameter away from the check valve to avoid hitting the discs. The disc edge will extend past the flange face, so it may interfere with the operation of the adjacent valve.

**⚠ CAUTION: When installing the double disc check valve in horizontal piping systems be sure to install the valve in an orientation that puts the disc hinge in the vertical position.**

Lower valve into position between mating flanges using slings or chains wrapped around valve body. Never support the valve from within the valve body or valve trim. On larger valves a tapped hole on the top of the valve allows for the use of a lifting eye.

#### Maintenance

No Maintenance or lubrication is required.

#### Spare Parts

Stocking of spare parts is not recommended.

### DESCRIPTION OF OPERATION

The double disc check valve is designed to prevent flow reversal in applications where this situation can occur. In pumping applications the pump will start the flow of water in the direction noted in chart below.

The flow of water will push against the twin discs and force them back away from the body seat. The water will then flow through the valve between the two discs and body seat, as long as the water pressure keeps the valve open. When the pump stops and water ceases to flow the spring behind the discs will push the discs closed against the body and seal off the flow of water in the opposite direction. The disc closure occurs before the flow of water can reverse thus silencing the operation of the check valve. Typical check valve operation will cause valve slam or water hammer which is due to some degree of flow reversal.

The only moving parts in the double disc check valve are the twin discs and spring. The discs and spring are guided in the body with a hinge pin and a full open disc stop pin. The pins are captured within the valve body and a dampening material is used to eliminate vibration. The resilient body seat provides a drop tight seal for any applicable flow media.

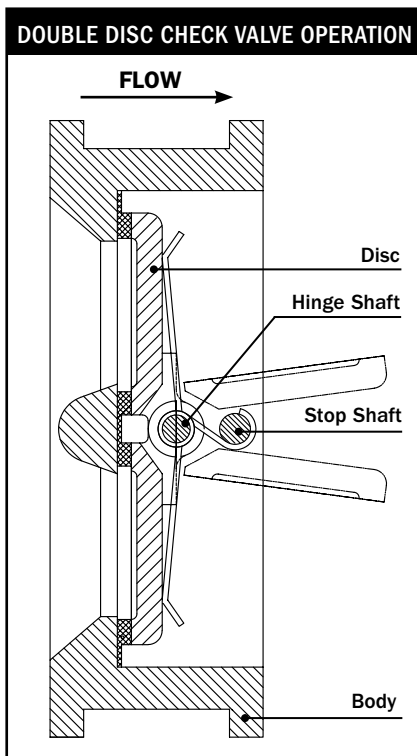

### TROUBLESHOOTING

PROBLEM	SOLUTION
Valve experiences noisy vibration or emits a chatter sound	<ul style="list-style-type: none"> <li>Flow velocity needs to be at least 4 feet per second or better. A partially open valve will wear prematurely. Verify that there are at least 3 pipe diameters of straight pipe upstream of valve.</li> </ul>
Valve Leakage	<ul style="list-style-type: none"> <li>In horizontal piping applications verify disc pin is in vertical position.</li> <li>Debris caught in valve. Remove valve and inspect seating surfaces.</li> </ul>
Valve does not allow flow to occur	<ul style="list-style-type: none"> <li>Verify flow arrow is in proper orientation.</li> <li>Verify debris is not in line.</li> </ul>
Valve Slams	<ul style="list-style-type: none"> <li>Remove valve and inspect spring. Spring may have broken.</li> <li>Disc bushing is getting clogged with debris – disc is getting stuck open.</li> </ul>

### DISASSEMBLY / REASSEMBLY

#### Disassembly

**⚠ CAUTION:** All work performed on any check valve should be made when the valve is fully removed from the pipeline and executed by a trained mechanic using the correct tools.

- Lay valve flat on bench with flow arrow facing up. Remove square head threaded hinge pin and stop pin retainers and rubber vibration material.
- Remove pins by driving out from opposite end using a pin punch, while holding down the springs. Use a board and clamp to retain the spring.

**⚠ WARNING:** The valve spring can rapidly uncoil and cause bodily injury. Secure spring with boards and clamps during maintenance.

- Lift discs from body. Inspect pins and seats for wear. The shaft diameter is about 1/32" smaller in diameter than the hole in the disc lugs. Some minor dents and

discoloration are normal. Wear in the resilient seat will cause leakage and require valve replacement or refurbishment.

- Inspect spring for wear or cracks.
- Remove bearings and inspect for wear.

#### Reassembly

**NOTE:** Prior to assembly all parts should be cleaned and body gasket faces should be wire brushed to remove any residual gasket material to ensure an effective sealing surface. Never use old or used gaskets during installation.

- Lay body on flat surface with arrow facing upwards. Place the two discs with the machined seating surface down on the body seating surface. Align the disc lugs with the body pin holes.
- Place washers on top of discs and partially install disc pin.
- Install one end of spring, hooking

spring arm behind the disc lug. Torque spring one half turn and hook other arm to the opposite disc lug. Insert shaft further to hold spring in place and install remaining washers on bottoms of discs. Complete insertion of disc shaft.

- Install stop shaft.
- Install pipe plugs, using suitable thread compound to insure seal and to prevent galling.

# 740G DOUBLE DISC CHECK VALVE

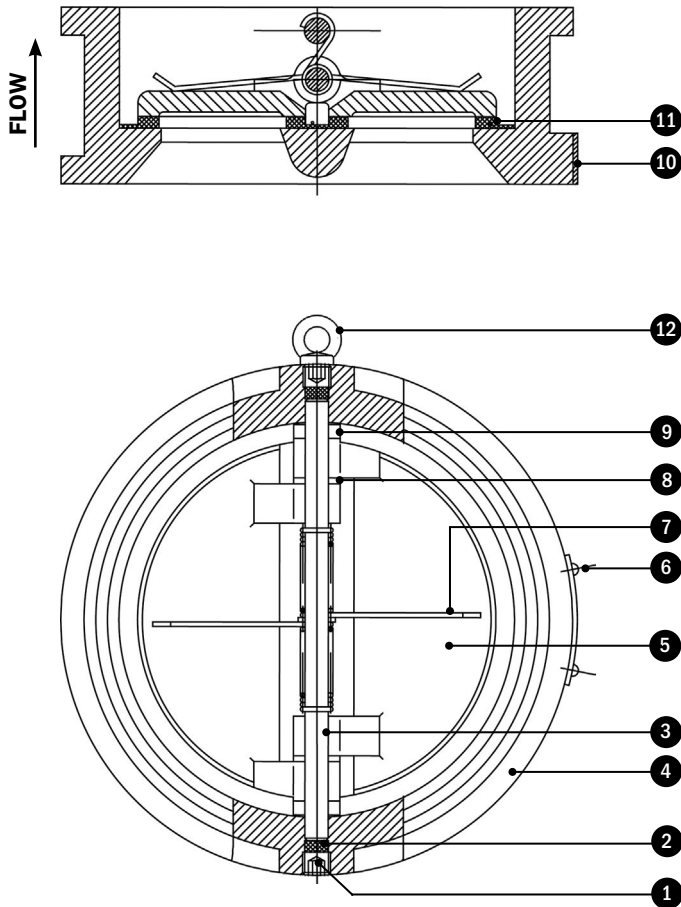

## PARTS LIST

ID	DESCRIPTION	MATERIAL
1	Plug	ASTM 1035
2	Seal	EPDM
3	Shaft	304 Stainless Steel
4	Body	Ductile Iron ASTM A536
5	Disc	304 Stainless Steel
6	Screw	Aluminum
7	Spring	316 Stainless Steel
8	Washer 1	304 Stainless Steel
9	Washer 2	304 Stainless Steel
10	Name Plate	304 Stainless Steel
11	Seat	EPDM
12*	Lifting Ring	ASTM 1035

\*Only for 8" and larger valves

TO ORDER: Contact our Parts Department.

Pratt  
 401 South Highland Avenue  
 Aurora, IL 60506-5563  
 Attn: Parts Manager  
 630.844.4000

When ordering parts, please include the serial number located on the valve tag and description of part requested.

**MUELLER® | ECHOLOGICS® | HYDRO GATE® | HYDRO-GUARD® | JONES® | MI.NET® | MILLIKEN® | PRATT® | SINGER® | U.S. PIPE VALVE & HYDRANT**

---

1.800.423.1323 - [www.prattvalve.com](http://www.prattvalve.com) - [moreinfo@muellercompany.com](mailto:moreinfo@muellercompany.com)

**INTERNATIONAL** - 1.423.490.9555 - [www.mueller-international.com](http://www.mueller-international.com) - [international@muellercompany.com](mailto:international@muellercompany.com)

Mueller refers to one or more of Mueller Water Products, Inc., a Delaware corporation ("MWP"), and its subsidiaries. MWP and each of subsidiaries are legally separate and independent entities when providing products and services. MWP does not provide products or services to third parties. MWP and each of its subsidiaries are liable only for their own acts and omissions and not those of each other. MWP brands include Mueller®, Echologics®, Hydro Gate®, Hydro-Guard®, Jones®, Mi.Net®, Milliken®, Pratt®, Singer®, and U.S. Pipe Valve & Hydrant. Please see [www.muellerwp.com/about](http://www.muellerwp.com/about) to learn more.



Copyright © 2018 Henry Pratt Company, LLC. All Rights Reserved. The trademarks, logos and service marks displayed in this document are the property of Mueller Water Products, Inc., its affiliates or other third parties. Products above marked with a section symbol (§) are subject to patents or patent applications. For details, visit [www.mwppat.com](http://www.mwppat.com). These products are intended for use in potable water applications. Please contact your Mueller Sales or Customer Service Representative concerning any other application(s).