

SUPPLIED WITH 8 MILS AMERLOCK 2 RED OXIDE EPOXY INTERIOR AND EXTERIOR OF THE VALVE

REFERENCE ONLY

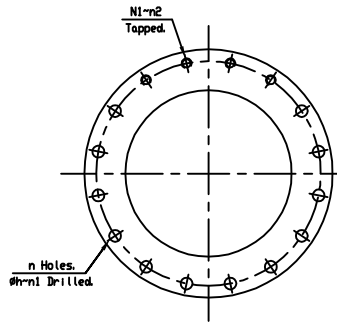
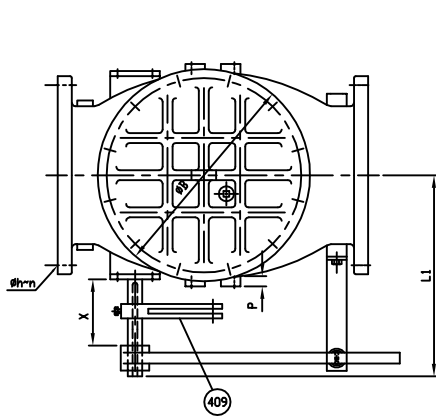

Detail of flange for size 16\"/>

VIEW A

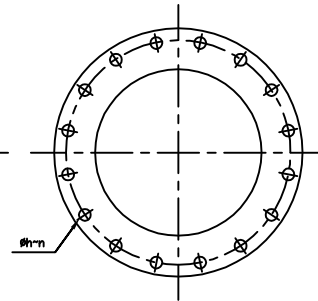

Detail of flange for size 16\"/>

VIEW B

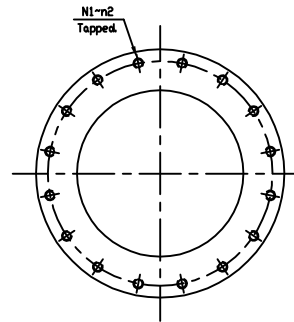

Detail of flange for size 18\"/>

VIEW A, B

Marking

SIZE (INCH) \odot
 CCNE SCI
 150 CWP YEAR
 AWWA C508 POURING DATE
 SERIES 9000

527	Stud Nut and Nut	Zinc Coated Steel	A 307 Grade B	1
526	Arm B	Zinc Coated Steel	A 36	1
525	Tear Drop Bolt	Zinc Coated Steel	A 307 Grade B	1
409	Tear Drop	Ductile Iron	A 536 Gr. 65-45-12	1
380	Key B	Stainless Steel	A 276 Type 304	2
352	O-Ring C	Rubber (Buna N)	D 2000 BK 707	2
351	O-Ring B	Rubber (Buna N)	D 2000 BK 707	2
324	Cover Gasket	Rubber (Buna N)	D 2000 BK 807	1
283	Arm Bolt	Zinc Coated Steel	A 307 Grade B	1
220	Snap Ring	Stainless Steel	A 276 Type 420	2
198	End Plate Bolt	Zinc Coated Steel	A 307 Grade B	1
197	Spring	Zinc Coated Steel	Spring Steel	1
194	Cover Bolt & Nut	Zinc Coated Steel	A 307 Grade B	1
188	Disc Seat Bolt	Stainless Steel	A 276 Type 304	1
166	Plug #1	Stainless Steel	A 276 Type 304	1
161	Key A	Stainless Steel	A 276 Type 304	2
159	Hinge Pin	Stainless Steel	A 276 Type 316	1
155	Arm	Ductile Iron	A 536 Gr. 65-45-12	1
076	Bushing (B)	Bronze	B 62	1
075	Bushing (A)	Bronze	B 62	1
062	Disc Seat Ring	Rubber (Buna N)	D 2000 BK 807	1
061	Body Seat Ring	Stainless Steel	A 276 Type 316	1
057	End Plate (B)	Ductile Iron	A 536 Gr. 65-45-12	1
038	Stopper	Stainless Steel	A 276 Type 304	1
024	Seat Holder	Ductile Iron	A 536 Gr. 65-45-12	1
016	Bolt	Zinc Coated Steel	A307 Grade B	1
015	End Plate (A)	Bronze	B 62	1
014	Cover	Cast Iron	A 126 Class B	1
003	Disc	Ductile Iron	A 536 Gr. 65-45-12	1
001	Body	Cast Iron	A 126 Class B	1
ND	PARTS	MATERIAL	ASTM DESIGNATION	QTY

△



Body Seat Screw in.

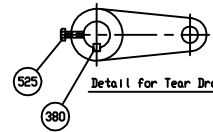

Detail for Tear Drop

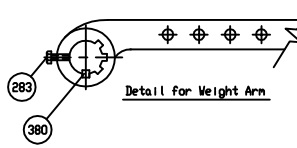

Detail for Weight Arm

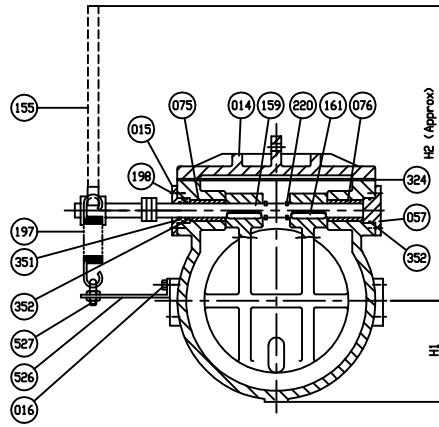
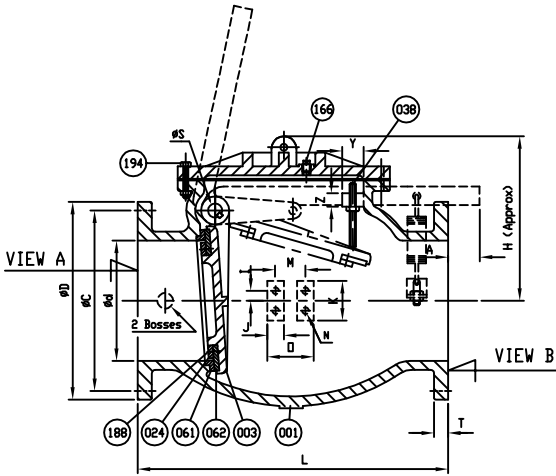

SIZE in. mm.	L	ANSI B16.1 CL. 125					A	øS	øB	H	H1	H2	I	J	K	M	N	N1	n1	n2	Ø	P	L1	X	Y	Z
		øD	øC	øh	n	T																				
14 (350)	30	21	18 3/4	1 1/8	12	1 3/8	6.5	3	22.24	21 1/16	12 1/16	43 3/8	1	2 1/8	4 1/2	4	3/4x10v<UNC>	-	-	-	6	1 1/2	23 1/2	9.5	2.5	1 1/2
16 (400)	30 1/2	23 1/2	21 1/4	1 1/8	16	1 1/16	8.75	3 1/2	24 1/8	24	13 3/16	50 1/4	1	2 1/8	4 1/2	4	3/4x10v<UNC>	1x8v<UNC>	12	4	6	1 1/2	26 1/8	10.75	2.5	1 1/2
18 (450)	33 1/2	25	22 3/4	1 1/4	16	1 3/16	8.25	3 3/4	28.35	27 3/16	14 3/8	55 3/4	1	2 1/8	4 1/2	4	3/4x10v<UNC>	1 1/8x7v<UNC>	-	16	6	1 1/2	28 3/4	11.25	3	1 3/4
20 (500)	40	27 1/2	25	1 1/4	20	1 1/16	8	4	31	31 5/16	15 3/8	62 1/8	1.5	2 1/2	5	4 1/2	1x8v<UNC>	-	-	-	7	2	32 1/2	11.5	3.5	2
24 (600)	46	32	29 1/2	1 3/8	20	1 7/8	7	4	35.85	35 1/4	17 3/8	69 5/8	1.5	2 1/2	5	4 1/2	1x8v<UNC>	-	-	-	7	2	34 3/8	11.5	3.5	2

MATERIAL LIST			
HYDRD SHELL		300	PSI.
HYDRD VALVE SEAT		150	PSI.
HYDRD BACK SEAT		-	PSI.
AIR SEAT		-	PSI.
STEAM		-	PSI.
TEST PRESSURE			
WORKING PRESSURE		150	PSI.

PRATT

SCALE	DRG.	J. COLPAN	DATE	07/03/14	REV. DRG.
N.T.S.	CHK.	AA	APP.	JW	USA1350C
TITLE	SIZE 14" TO 24" SWING CHECK VALVE AWWA C508 STAINLESS STEEL BODY SEAT RING & BUNA N DISC SEAT RING WITH ONE LEVER AND SPRING				
TYPE	9001AS1LS		DRG. NO.	HP90133	REV.
					2

DS01 ISSUED : 240640 REVISED:--USA1350A-->CHANGE F--F-THREAD UNC

REVISION 1, CHANGED ITEM 166 MTRL. TYPE FROM MALLEABLE IRON A47 TO, UJC, 03/08/11, ECR# 456

REVISION 2, ADDED ITEM 220 SNAP RING MATERIAL TYPE, UJC, 04/04/11, ECR# 491