

VALVE SIZE	A	C	D	E	F	G	H	J	K	L	M	N	P	Q	FLANGE STYLE	GEAR SIZE
14	17	13	14	18.75	21	1.13	8	1	4	1.38	15.06	18	11.63	4.63	CL125	M80
16	17.75	14	16	21.25	23.25	1.13	8	1	8	1.44	15.81	18	11.63	4.63	CL125	M80
18	21.50	15	18	22.75	25	1.25	8	1.13	8	1.56	17	18	11.63	4.63	CL125	M80
20	23.50	16	20	27.50		1.25	12	1.13	8	1.69	20.44	18	11.63	4.63	CL125	M80

ABOVE GROUND GEAR
W/ HANDWHEEL
OPTION

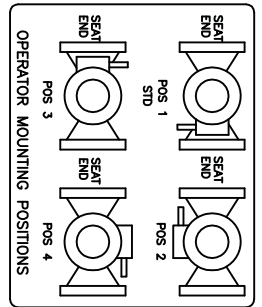
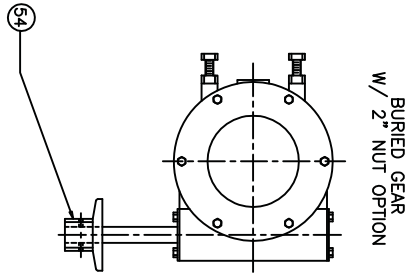
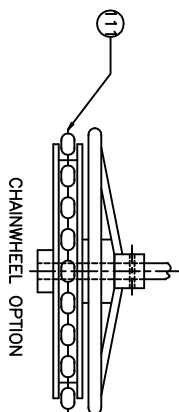
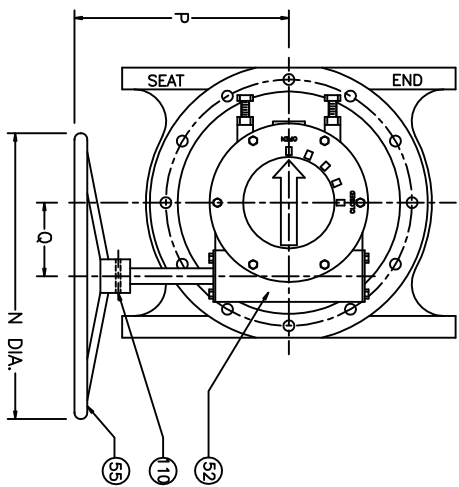

REFERENCE ONLY

THIS DRAWING IS THE PROPERTY OF
HENRY PRATT COMPANY
AND MUST NOT BE USED IN ANY WAY
PREJUDICIAL TO THEIR INTERESTS

* OPTION

111	1	CHAINWHEEL	DUCTILE IRON
110	1	SPRING PIN	SPRING STEEL
55	1	HANDWHEEL	DUCTILE IRON
54	1	2" NUT	DUCTILE IRON
53	2	SLEEVE BEARING	BRONZE
52	1	WORM GEAR	STEEL
51	1	QUADRANT	DUCTILE IRON
50	1	GEAR OPERATOR	
14	AR	H.H.CAP SCREW	STEEL/ZINC
13	1	TRUNION COVER	CAST IRON
12	1	O RING	ELAS. AS SPEC.
11	1	SUPPORT WASHER	STEEL
10	2	GRIT SEAL	PTFE
9	1	SEAL RETAINING RING	BRASS
8	AR	H.H.CAP SCREW	STEEL/ZINC
7	1	O RING	ELAS. AS SPEC.
6	2	U CUP SEALS	ELAS. AS SPEC.
5	2	SNAP RING	SPRING STEEL
4	2	SLEEVE BEARING	STN. STEEL
3	1	PLUG	DUCTILE IRON
2	1	CAP	CAST IRON
1	1	BODY	CAST IRON



J SIZE OF TAPPED HOLES
K NO. OF TAPPED HOLES
G DIA. OF HOLES
H NO. OF HOLES

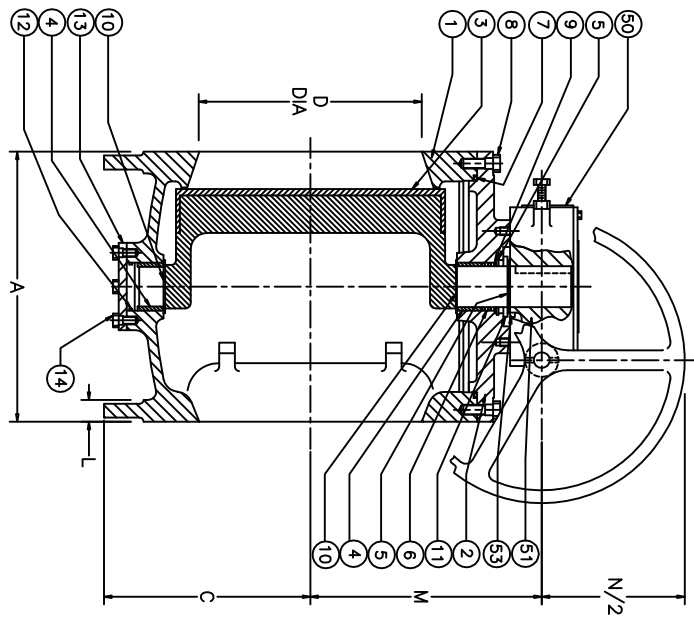
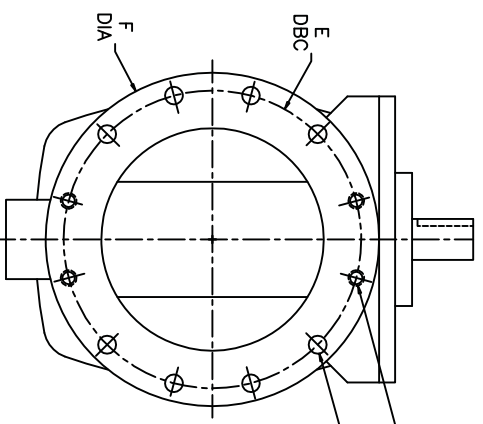

NUM	ISSUE	DATE	REVISIONS	BY	CR	DATE	SCALE
1	7/98	REMOVED 24"-72" CR				01/96	NONE
2	3/06	CHG 18" H.H.C TO 8 F.S					
3	2/10	CHG ITEM 50 TO DUCTILE IRON (ECH# 2592)					
4	2/13	SOUL MNT. LIST UPDATED/AA					
5	3/13	CORRECTION TO "1" DIA					

HENRY PRATT COMPANY
 HENRY PRATT COMPANY, ILL.
 CHK'D
 DIMENSIONS INCHES
 TITLE: 14"-20" PLUG VALVE, FLANGED, GEAR OPERATED W/HANDWHEEL, 2" NUT, OR CHAINWHEEL OPTION
 DWG. NO. HP49069