

THIS DRAWING IS THE PROPERTY OF
HENRY PRATT COMPANY
AND MUST NOT BE USED IN ANY WAY
PREJUDICIAL TO THEIR INTERESTS

SIZE	A	B	C	D	E	F	G	H	WT. LB.
3	2.63	2.06	3.75	5.25	0.50	2.13	3.75	5.00	18
4	3.63	3.03	2.25	6.88	0.44	2.13	7.00	6.00	13
6	5.44	4.75	2.75	8.75	0.56	3.25	7.25	7.13	27
8	7.25	6.44	2.88	11.00	0.63	4.00	8.75	8.06	42
10	8.50	7.63	3.13	13.13	0.88	4.88	11.25	9.50	63
12	10.44	9.50	3.50	16.13	0.88	5.88	13.25	13.88	96

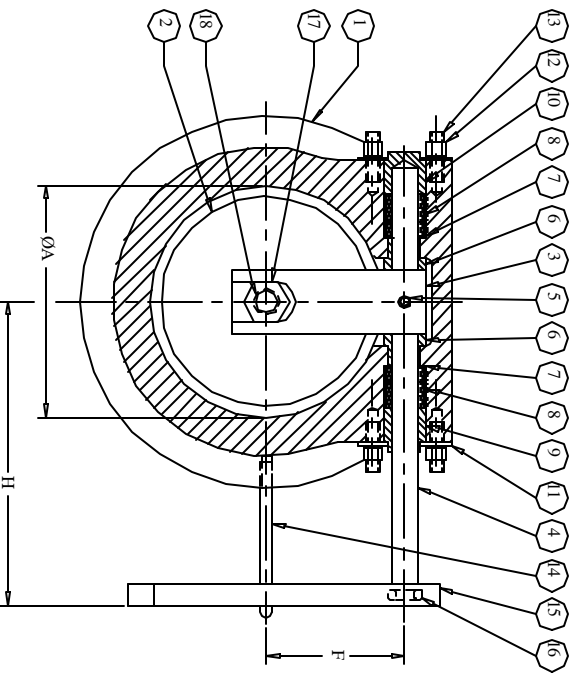

RIGHT HAND SHOWN

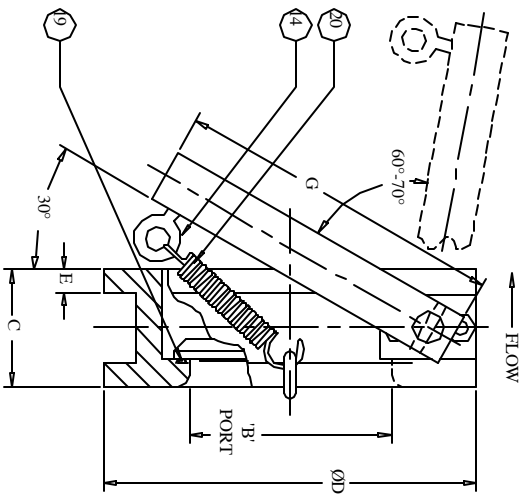

NOTE:
1. SPECIFY RIGHT HAND OR
LEFT HAND WHEN ORDERING.

ITEM	QTY.	DESCRIPTION	MATERIAL
20	1	SPRING	STEEL
19	1	O-RING	BUNA-N
18	1	THREADED ROD	316 S.S.
17	1	NUT	316 S.S.
16	1	SPRING PIN	STEEL
15	1	SPRING ARM	STEEL
14	2	EYESCREW	STEEL
13	4	THREADED ROD	STEEL
12	4	NUT	STEEL
11	2	PLATE	STEEL
10	1	BLIND GLAND	BRONZE
9	1	GLAND	BRONZE
8	6	PACKING	P.T.F.E.
7	2	WASHER	BRONZE
6	2	BUSHING	BRONZE
5	1	S.H. CAP SCREW	316 S.S.
4	1	SHAFT	316 S.S.
3	1	DISC ARM	316 S.S.
2	1	DISC	316 S.S.
1	1	BODY	A126 CL. B IRON

PRATT
Henry Pratt Company

DATE: _____ REVISIONS: _____ BY: _____

3"-12" WAFER CHECK VALVE
DIMENSIONS INCHES
DWG. NO. HP-500719