

REFERENCE ONLY

SIZE	2	2.5	3	4	5	6	8	10	12	14	16	18	20	24
A	4.00	5.50	6.00	7.25	8.50	9.75	12.50	15.50	14.25	15.75	17.63	18.75	20.63	24.00
B	6.00	7.00	7.50	9.00	10.00	11.00	13.50	16.00	19.00	21.00	23.50	25.00	27.50	32.00
C	4.63	6.00	6.88	8.50	9.75	11.13	16.13	17.88	19.13	22.50	26.00	29.00	32.75	34.00
D	2.13	2.75	3.00	4.00	5.00	6.00	8.00	10.00	12.00	13.88	15.25	16.75	19.25	20.75
E	4.75	5.50	6.00	7.50	8.50	9.50	11.75	14.25	17.00	18.75	21.25	22.75	25.00	29.50
F	0.62	0.69	0.75	0.94	0.94	1.00	1.12	1.19	1.25	1.38	1.44	1.56	1.69	1.88
G	0.75	0.75	0.75	0.75	0.88	0.88	1.00	1.00	1.00	1.12	1.12	1.25	1.25	1.38
H	4.00	4.00	4.00	8.00	8.00	8.00	8.00	12.00	12.00	12.00	16.00	16.00	20.00	20.00
WT	14.30	24.40	28.60	44.10	56.00	83.40	142.40	219.00	362.60	465.10	660.50	919.00	1174.00	1586.00

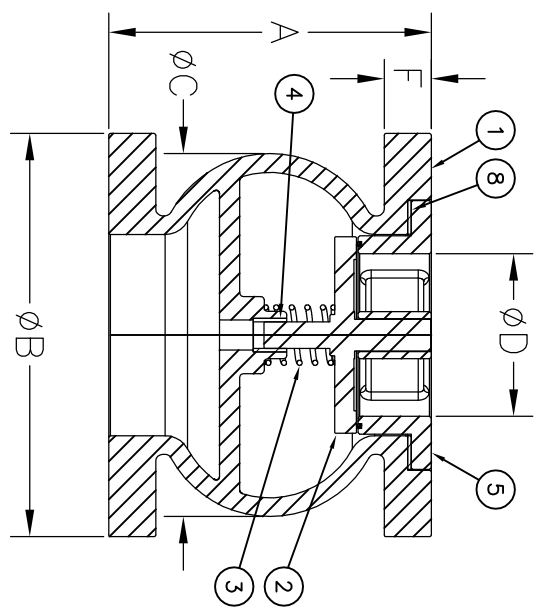

SECTION A-A

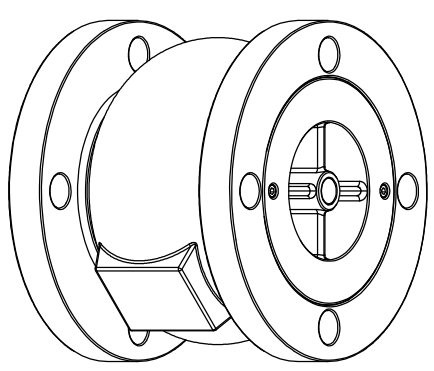

ISOMETRIC VIEW

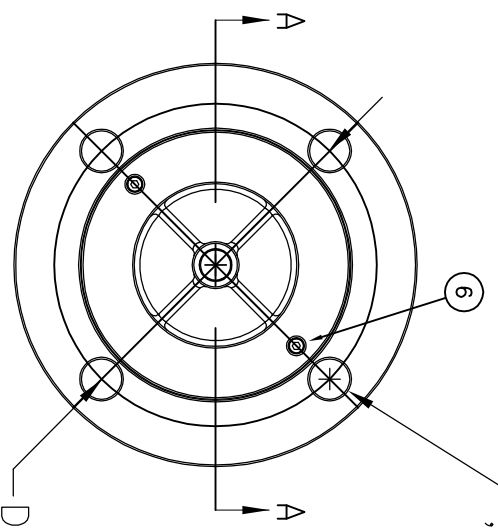

'G' DIA. OF HOLES
'H' NO. OF HOLES

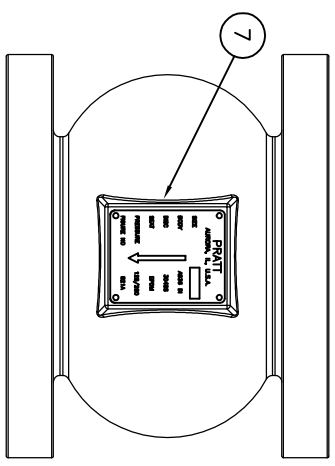

'E',
'D.B.C.

NOTE: Δ

1 - 10 TO 12 MILS INTERIOR AND EXTERIOR AMERLOCK 400 BLUE EPOXY

ITEM	QUANTITY	DESCRIPTION	MATERIAL
8	1	GASKET	EPDM
7	1	NAME PLATE	ALUMINUM
6	1	CAP SCREW	304 STAINLESS STEEL
5	1	SEAT	304 STAINLESS STEEL / EPDM
4	1	BUSHING	304 STAINLESS STEEL
3	1	SPRING	304 STAINLESS STEEL
2	1	DISC	304 STAINLESS STEEL
1	1	BODY	DUCTILE IRON

MATERIAL LIST

THIS DRAWING IS THE PROPERTY OF
HENRY PRATT CO.
AND
MUST NOT BE USED IN ANY WAY
PREJUDICIAL TO THEIR INTERESTS

DRAWN	J. COLPAN
CHECKED	A. JACKSON
APPROVED	B. JACKSON
DATE	04-06-2010
REF. DWG	-

TITLE:
2" TO 24" FIG. 821A
GLOBE STYLE CHECK VALVE
250 WOG

ISSUE	CHANGE NO. OR DESCRIPTION	DATE	BY	TYPE
1	ADDED PAINT INFORMATION NOTE 3	07/12	J.C.	-
2	-	-	-	-
3	-	-	-	-
4	-	-	-	-

DRAWING NO.: HP50614