

COVER BOLTS/NUTS		
TYPE	MATERIAL	
STANDARD	STEEL/ZINC	✓
S1	304 STN. STEEL	
S3	316 STN. STEEL	

Remark - Flanged dimensions follow ANSI B16.1 CL. 125

NO.	PARTS	MATERIAL	ASTM. DESIGNATION	Q' TY
462	Retaining Plug	Brass	B 21	1
351	O-Ring	Rubber (Buna N)	D 2000 BK 707	2
329	Cover O-Ring	Rubber (Buna N)	D 2000 BK 807	1
327	Gasket	Rubber (Buna N)	D 2000 BK 807	2
324	Cover Gasket	Rubber (Buna N)	D 2000 BK 807	1
262	Disc Bolt	Stainless Steel	A 276 Type 304	1
199	Seat Holder Bolt	Stainless Steel	A 276 Type 304	1set
197	Weight Bolt	Zinc Coated Steel	A 307 Grade B	2
194	Cover Bolt & Nut	See Table	See Table	1set
166	Plug $\phi 1/2'$	Stainless Steel	A 276 Type 304	1
161	Key	Stainless Steel	A 276 Type 304	1
159	Hinge Pin	Stainless Steel	A 276 Type 304	1
155	Weight Arm	Ductile Iron	A 536 Gr. 65-45-12	1
088	Seat Nut	Brass	B 21	1
062	Disc Seat Ring	Rubber (Buna N)	D 2000 BK 807	1
061	Body Seat Ring	Bronze	B 62	1
024	Seat Holder	Ductile Iron	A 536 Gr. 65-45-12	1
016	Weight	Cast Iron	A 126 Class B	1
023	Arm	Ductile Iron	A 536 Gr. 65-45-12	1
014	Cover	Cast Iron	A 126 Class B	1
003	Disc	Cast Iron	A 126 Class B	1
001	Body	Cast Iron	A 126 Class B	1

MATERIAL LIST			
HYDRD SHELL		300	PSI.
HYDRD VALVE SEAT		150	PSI.
HYDRD BACK SEAT		—	PSI.
AIR SEAT		—	PSI.
STEAM		—	PSI.

TEST PRESSURE			
WORKING PRESSURE		150	PSI.



SCALE	DR. JON COLPAN	DATE 10/20/10	REF. DWG.
N.T.S.	CHK. APP.	E.C.N.	USA1323D

TITLE
 SIZE 18" SWING CHECK VALVE AWWA C508
 BRONZE BODY SEAT RING & BUNA N DISC SEAT RING
 WITH ONE LEVER AND WEIGHT

TYPE:	8001AB1LW	DWG NO.	HP80007	REV.	4
-------	-----------	---------	---------	------	---

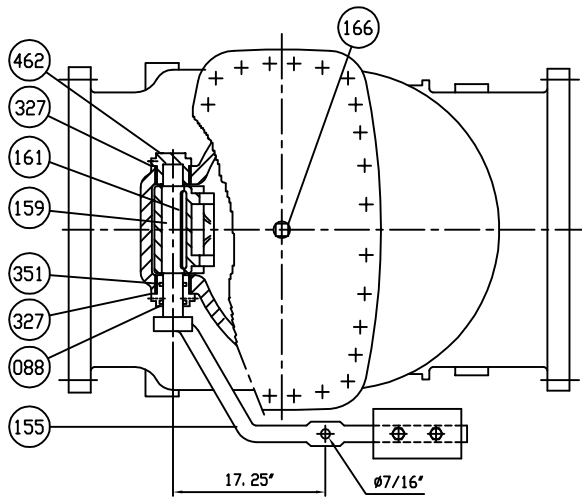

Marking
 18 \oplus
 CCNE 200
 150 PSI CI
 AWWA C508 SERIES 8000
 CI \Rightarrow

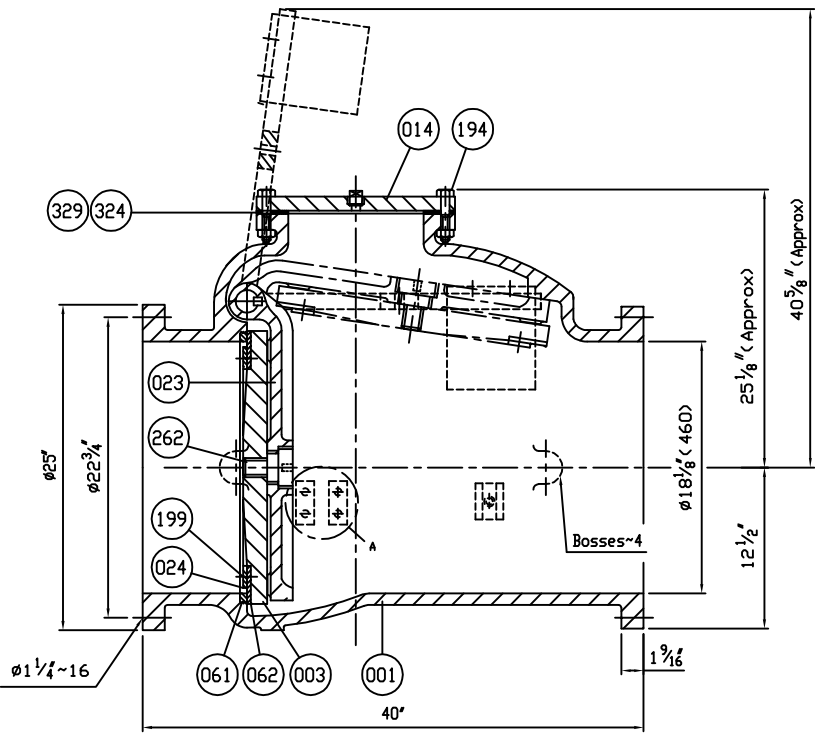
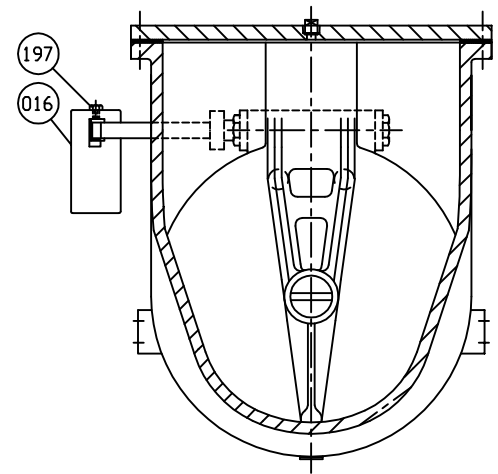
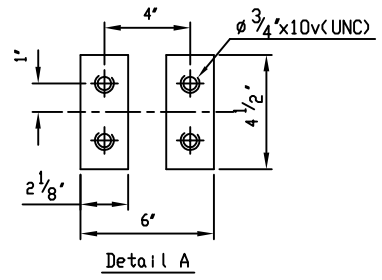

DS01 ISSUED : 240640 REVISED:--

REVISION 1, CHANGED ITEM 166 MTRL. TYPE FROM MALLEABLE IRON A47 TO, UJC, 03/08/11, ECR# 456
 REVISION 3, ADDED COVER O-RING TO MATERIAL TABLE AND REMOVED PAINT NOTE, AA, 11/28/17

REVISION 2, ADDED BOLTING TABLE TO DWG, AA, 04/29/13
 REVISION 4, ADDED ITEM 329 BALLOON TO DWG AND REMOVED NOTE IN TITLE BLOCK, AJM, 04/19/18