

ACTUATOR POSITION 1

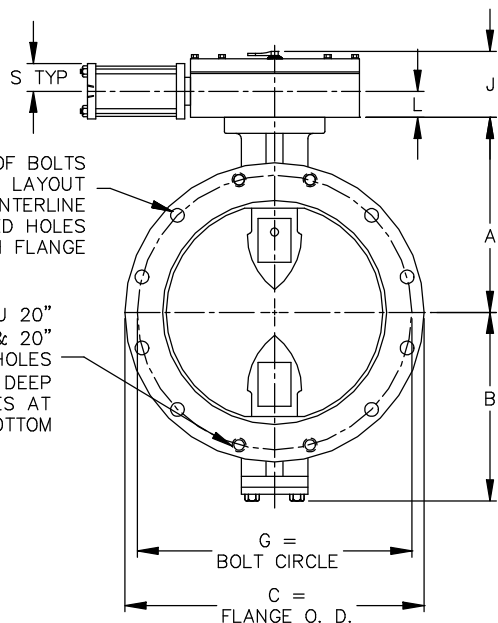

F = NO. & SIZE OF BOLTS
 125# STANDARD LAYOUT
 STRADDLE CENTERLINE
 INCLUDES TAPPED HOLES
 EACH FLANGE

CAST STEEL BODIES 4" THRU 20"
 & CAST IRON BODIES 18" & 20"
 HAVE 4 TAPPED HOLES
 "F" SIZE UNC-2B X "E" DEEP
 PER FLANGE. 2 HOLES AT
 TOP AND 2 HOLES AT BOTTOM

NOTES:

- ALL DIMENSIONS SHOWN IN INCHES.
- "D" DIMENSION $\pm 1/16$ " FOR 3" THRU 10" VALVES.
 "D" DIMENSION $\pm 1/8$ " FOR 12" THRU 20" VALVES.
- FOR BOLTS SMALLER THAN $\phi 1-3/4$, BOLT HOLES WILL BE $1/8$ " LARGER THAN DIAMETER OF BOLT.
 FOR BOLTS $\phi 1-3/4$ OR LARGER, BOLT HOLES WILL BE $1/4$ " LARGER THAN DIAMETER OF BOLT.
- DIMENSIONS AND DRILLING OF END FLANGES CONFORM TO THE AMERICAN CAST IRON FLANGE STANDARDS, CLASS 125 (B16.1).
- VALVES MANUFACTURED & TESTED IN ACCORDANCE WITH AWWA SPECIFICATION C-504 LATEST REVISION, CLASS 150B.
- RECOMMENDATION FOR MATING FLANGES: WHERE INSULATING BUSHINGS ARE USED, IT IS NECESSARY THAT BOLT HOLES BE DRILLED OVERSIZE BY AN AMOUNT EQUAL TO TWO TIMES THE INSULATING SLEEVE THICKNESS TO MAINTAIN THE SAME MINIMUM CLEARANCE FOR BOLTS.

7. RECOMMENDED FILTRATION FOR CYLINDER SUPPLY MEDIA

AIR	50 MICRONS (DRY)
OIL	150 MICRONS
WATER	150 MICRONS

* OPEN & CLOSED PORTS ARE REVERSED ON THESE SIZES.

VALVE SIZE	A	B	C	D	E	F	G
3	4-3/4	3-7/8	7-1/2	5	3/4	4--5/8	6
4	5-1/2	4-1/8	9	5	15/16	8--5/8	7-1/2
6	6-1/2	5-1/8	11	5	1	8--3/4	9-1/2
8	7-3/4	6-1/2	13-1/2	6	1-1/8	8--3/4	11-3/4
10	9	9-7/8	16	8	1-3/16	12--7/8	14-1/4
12	10-1/2	11-3/8	19	8	1-1/4	12--7/8	17
14	11-7/8	12-3/4	21	8	1-3/8	12--1	18-3/4
16	13-1/2	14-3/8	23-1/2	8	1-7/16	16--1	21-1/4
18	14-3/8	15-1/4	25	8	1-9/16	16--1-1/8	22-3/4
20	16	16-7/8	27-1/2	8	1-11/16	20--1-1/8	25

ACTUATOR SIZE	CYLINDER SIZE		J	L	M	N	P	Q	R	S	XX
	BORE	STROKE									
MDT-2S	2-1/2	4	4-11/16	2	2-1/8	2	4-1/2	4-1/4	13-1/16	1-3/4	3/8
MDT-2S	4	4	4-11/16	2	2-1/8	2	4-1/2	4-1/4	13-1/16	2-3/8	1/2
MDT-2S	5	4	4-11/16	2	2-1/8	2	4-1/2	4-1/4	13-13/16	2-7/8	1/2
MDT-3S	5	5-5/8	5-5/8	2-7/16	3-1/4	3-5/32	5-5/8	5-3/8	17-15/16	2-7/8	1/2
MDT-3S	8	5-5/8	5-5/8	2-7/16	3-1/4	3-5/32	5-5/8	5-3/8	18-5/8	4-3/8	3/4
MDT-3S	10	5-5/8	5-5/8	2-7/16	3-1/4	3-5/32	5-5/8	5-3/8	19-9/16	5-1/2	3/4
MDT-4S	5	8	6-3/8	2-27/32	3-3/8	4	7-5/16	6-3/4	21-1/4	2-7/8	1/2
MDT-4S	8	8	6-3/8	2-27/32	3-3/8	4	7-5/16	6-3/4	21-15/16	4-3/8	3/4
*MDT-4S	10	8	6-3/8	2-27/32	3-3/8	4	7-5/16	6-3/4	22-7/8	5-1/2	3/4
*MDT-4S	12	8	6-3/8	2-27/32	3-3/8	4	7-5/16	6-3/4	27-3/8	6-9/16	1
MDT-5	6	11	7-9/16	3-15/32	4-1/2	5-1/2	8-3/4	10	27-7/8	3-3/8	3/4
MDT-5	8	11	7-9/16	3-15/32	4-1/2	5-1/2	8-3/4	10	28-3/4	4-3/8	3/4
MDT-5	10	11	7-9/16	3-15/32	4-1/2	5-1/2	8-3/4	10	30-5/8	5-1/2	3/4
MDT-5	12	11	7-9/16	3-15/32	4-1/2	5-1/2	8-3/4	10	32	6-9/16	1
MDT-5	14	11	7-9/16	3-15/32	4-1/2	5-1/2	8-3/4	10	32	7-7/16	1

10/10/05	RCB	3-7/8 WAS 3-1/4, 4-1/8 WAS 3-1/2									
02-09-04	BB	CEG	NOTE 7 ADDED								
REV.-DATE	BY	APP.	REVISION	REV.-DATE	BY	APP.	REVISION				