

ITEM	DESCRIPTION	DESCRIPTION
1	HOUSING	CAST IRON ASTM A126 CLASS B
2	EXP. PLUG	STAINLESS STEEL TYPE 304
3	INSERT	NORYL GRADE GFN3-780
4	O-RING	BUNA-N
5	O-RING	BUNA-N
6	CAPSCREW	ALLOY STEEL (ZINC PLATED)
7	LEVER	DUCTILE IRON ASTM A536 GRADE (65-45-12)
8	BEARING	SINTERED BRONZE
9	LINK	CARBON STEEL
10	SET SCREW	ALLOY STEEL
11	RET. RING	CARBON STEEL
12	SLIDER TUBE	CARBON STEEL
13	ECCENTRIC BRG	SINTERED IRON
14	COVER	CAST IRON ASTM A126 CLASS B
15	CAPSCREW	STAINLESS STEEL TYPE 304

ITEM	DESCRIPTION	DESCRIPTION
16	SHIM	CARBON STEEL
17	THRUST WASHER	SINTERED BRONZE MDT4S/ IRON MDT3S
18	THRUST COLLAR	CARBON STEEL
19	DRIVE PIN	ALLOY STEEL
20	SLIDER NUT	DUCTILE IRON ASTM A-536 GRADE 65-45-12
21	BEARING	NYLON (MDT-4S ONLY)
22	BEARING	SINTERED BRONZE
23	SHAFT	CARBON STEEL
24	GASKET	BLENDED FIBER NITRILE BINDER
25	O-RING	BUNA-N
26	NUT	CAST IRON ASTM A48 CLASS 40 (MDT4S)
27	NUT	CAST IRON ASTM A-126 CLASS B (MDT3S)
28	PIN	STAINLESS STEEL TYPE 304

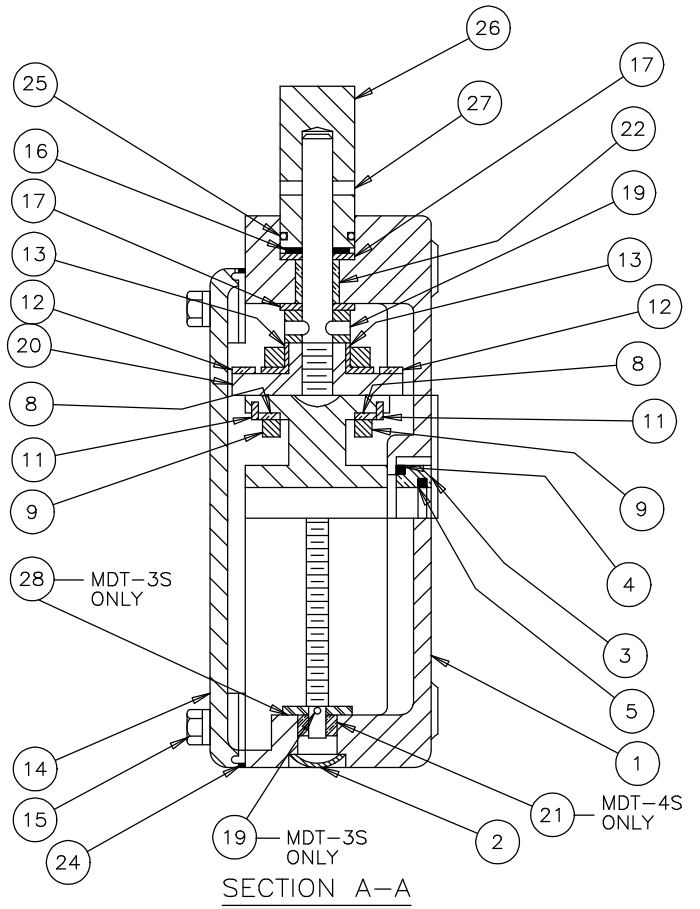
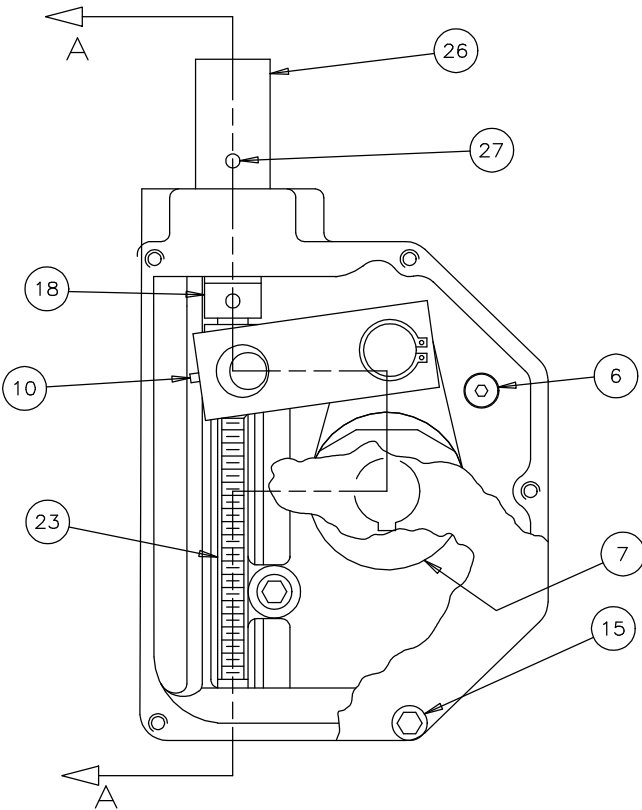

REV.	DATE	BY	DESCRIPTION	APP.	
PRATT HENRY PRATT COMPANY AURORA, ILL.					
CROSS SECTION PARTS AND MATERIAL LIST MDT-3S & 4S BURIED SERVICE NUT ACTUATOR					
SCALE <u>NONE</u> DATE <u>10-31-05</u>					
DRAWN BY <u>ES</u> CHECKED BY _____					
APPROVED _____ GA=BORDER					
DRWG. NO. GA-11499				REV o	A/C