

ITEM	DESCRIPTION	DESCRIPTION
1	HOUSING	CAST IRON ASTM A-48 CLASS 40
2	O-RING	RUBBER BUNA-N
3	O-RING	RUBBER BUNA-N
4	INSERT	NORYL GFN3-780
5	CAPSCREW	ALLOY STEEL
6	BEARING	SINTERED BRONZE
7	BEARING	SINTERED BRONZE
8	LEVER	DUCTILE IRON ASTM A-536 GRADE 80-60-03
9	LINK	CARBON STEEL
10	LINK BEARING	"DU" BEARING MATERIAL
11	SET SCREW	ALLOY STEEL
12	RETAINING RING	CARBON SPRING STEEL
13	SLIDE BLOCK	ALUMINUM BRONZE
14	ECCENTRIC BEARING	SINTERED METAL
15	SLIDER NUT	DUCTILE IRON ASTM A-536 GRADE 80-60-03

ITEM	DESCRIPTION	DESCRIPTION
16	SHAFT	CARBON STEEL AISI 12L14
17	THRUST COLLAR	CARBON STEEL
18	CAPSCREW	STAINLESS STEEL
19	THRUST RACE	HARDENED STEEL
20	ROLLER BEARING	HARDENED STEEL
21	COLLAR	DUCTILE IRON ASTM A-536 GRADE 80-60-03
22	ADAPTER	CAST IRON ASTM A-48 CLASS 40
23	O-RING	RUBBER BUNA-N
24	CAPSCREW	CARBON STEEL
25	COVER	CAST IRON ASTM A-48 CLASS 40
26	NUT	CAST IRON ASTM A-48 CLASS 40
27	SPRING PIN	STAINLESS STEEL TYPE 420
28	PIPE PLUG	MALLEABLE IRON (GALVENIZED)
29	EXPENSION PLUG	STAINLESS STEEL TYPE 304
31	COVER GASKET	NEOPRENE RUBBER

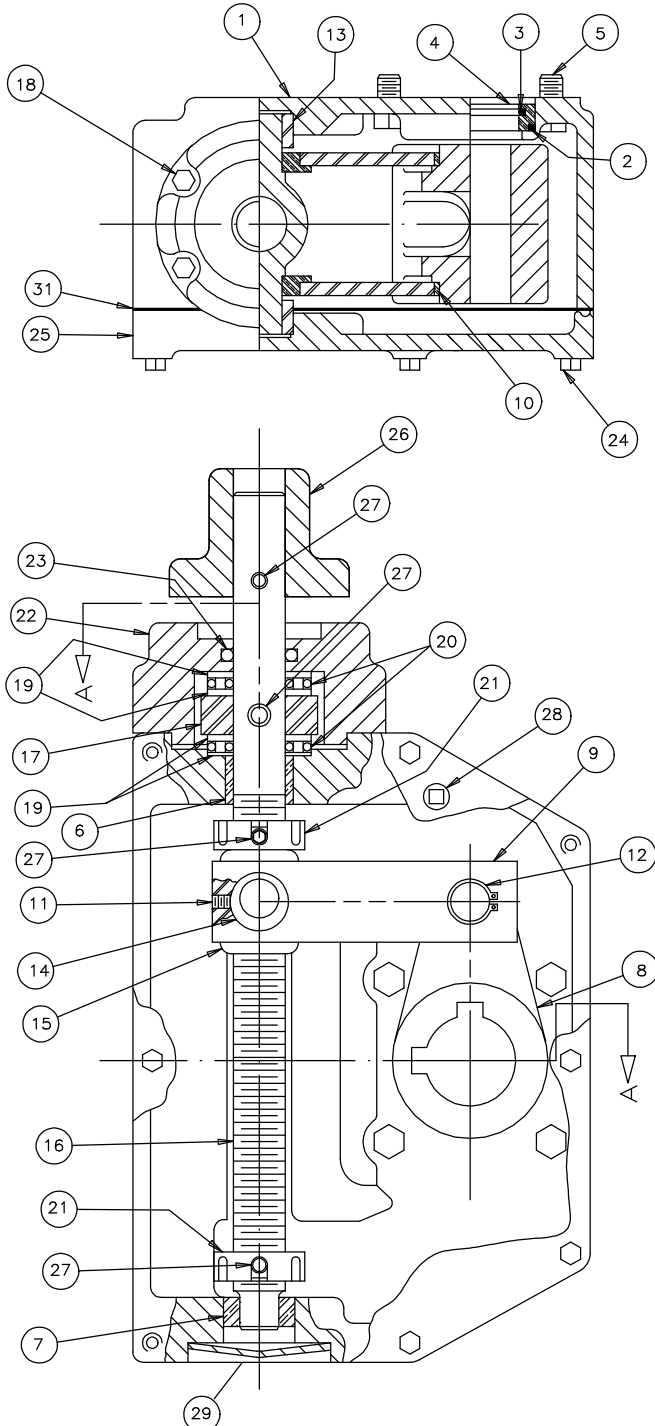

1	4/4/06	RCB	UPDATE MATERIALS	
REV.	DATE	BY	DESCRIPTION	APP.
PRATT			HENRY PRATT COMPANY AURORA, ILL.	
CROSS SECTION PARTS AND MATERIAL LIST MDT-5 BURIED SERVICE ACTUATOR				
SCALE		NONE	DATE 1-27-06	
DRAWN BY		CEG	CHECKED BY JR	
APPROVED		GA=BORDER		
DRWG. NO.	GA-11528		REV	1
				A/C