

ITEM	DESCRIPTION	MATERIAL
1	HOUSING	DUCTILE IRON ASTM A-536 GRADE 65-45-12
2	O-RING	RUBBER BUNA-N
3	SLIDER BLOCK	ALUMINUM BRONZE ASTM B-148 ALLOY C95400
4	CAPSCREW	CARBON STEEL
5	BEARING	SINTERED BRONZE
6	BEARING	SINTERED BRONZE
7	LEVER	DUCTILE IRON ASTM A-536 GRADE 80-60-06
8	LINK	CARBON STEEL AISI 1018
9	LINK BEARING	BRONZE
10	RETAINING RING	CARBON SPRING STEEL
11	EXPANSION PLUG	STAINLESS STEEL TYPE 304
12	SLIDER	ALUMINUM BRONZE ASTM A-150 ALLOY C63000
13	SHAFT	CARBON STEEL AISI B12L14 COLD DRAWN
14	THRUST COLLAR	CARBON STEEL (STRESS PROOF)
15	SPRING PIN	CARBON STEEL
16	INDICATOR	CAST IRON ASTM A-126 CLASS B
17	COLLAR	DUCTILE IRON ASTM A-536 GRADE 65-45-12
18	DRIVE GEAR	ALLOY STEEL
19	DRIVE PINION	CARBON STEEL
20	WIPER	RUBBER BUNA-N
21	NUT	CAST IRON ASTM A-48 CLASS 40
22	SPRING PIN	STAINLESS STEEL TYPE 420
23	PIPE PLUG	MALLEABLE IRON (GALVANIZED)
24	CLAMP COLLAR	CARBON STEEL
25	SCREW	CARBON STEEL

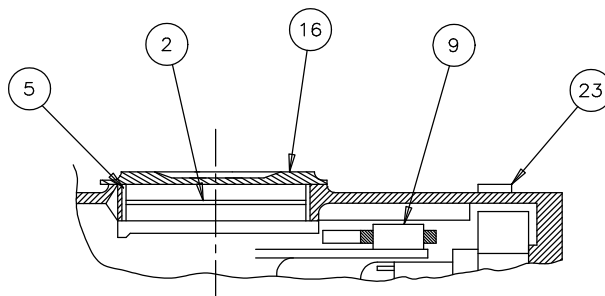
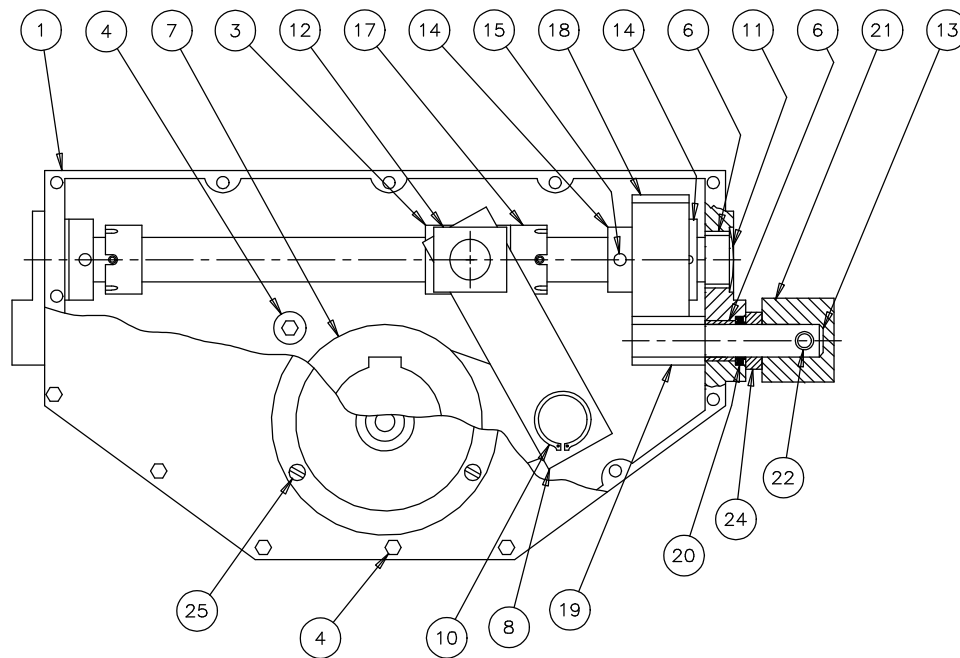

REV.	DATE	BY	DESCRIPTION	APP.

PRATT HENRY PRATT COMPANY
AURORA, ILL.

CROSS SECTION & MATERIALS LIST
MDT-5S BSN

SCALE NONE DATE 7-20-06

DRAWN BY CEG CHECKED BY

APPROVED GA=BORDER

DRWG. NO. GA-11615 REV 0 A/C