

MATERIAL OPTIONS AS CHECKED

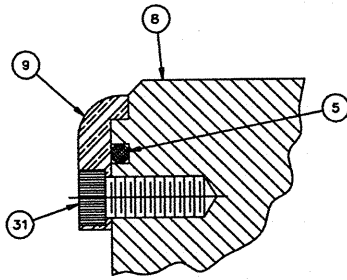

SEAT DETAIL  
6" 8" AND 10"  
BALL VALVES ONLY

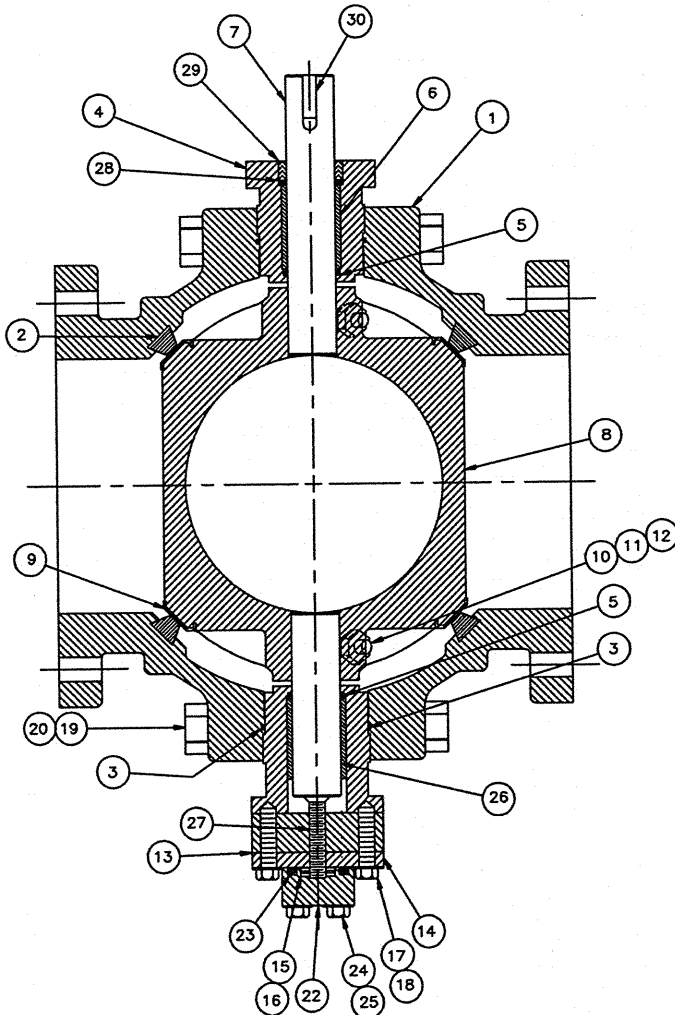

| ITEM NO. | DESCRIPTION         | MATERIALS                              | ✓ |
|----------|---------------------|--|---|
| 1        | END PIECE           | DUCTILE IRON ASTM A-536 (65-45-12)     |   |
|          |                     | CAST IRON ASTM A-126 CLASS B           |   |
| 2        | RUBBER SEAT         | RUBBER BUNA-N                          |   |
|          |                     | RUBBER EPDM                            |   |
| 3        | O-RING              | RUBBER BUNA-N                          |   |
|          |                     | RUBBER EPDM                            |   |
| 4        | CENTERPIECE         | DUCTILE IRON ASTM A-536 (65-45-12)     |   |
|          |                     | CAST IRON ASTM A-126 CLASS B           |   |
| 5        | O-RING              | RUBBER BUNA-N                          |   |
|          |                     | RUBBER EPDM                            |   |
| 6        | BEARINGS            | DURALON                                |   |
| 7        | TOP STUB SHAFT      | STAINLESS STEEL ASTM A-276 TYPE 304    |   |
|          |                     | STAINLESS STEEL ASTM A-276 TYPE 316    |   |
|          |                     | STAINLESS STEEL ASTM A-564 TYPE 630    |   |
|          |                     | 17-4 PH COND. H-1150                   |   |
| 8        | ROTOR               | CAST IRON ASTM A-48 CLASS 40           |   |
|          |                     | DUCTILE IRON ASTM A-536 (65-45-12)     |   |
| 9        | ROTOR EDGE          | STAINLESS STEEL ASTM A-240 TYPE 316    |   |
| 10       | TAPER PINS          | STAINLESS STEEL ASTM A-276 TYPE 304    |   |
|          |                     | STAINLESS STEEL ASTM A-276 TYPE 316    |   |
|          |                     | STAINLESS STEEL ASTM A-564 TYPE 630    |   |
|          |                     | 17-4 PH COND. H-1150                   |   |
| 11       | LOCKWASHERS         | STAINLESS STEEL ASTM A-276 TYPE 304    |   |
|          |                     | STAINLESS STEEL ASTM A-276 TYPE 316    |   |
| 12       | HEX NUTS            | STAINLESS STEEL ASTM A-276 TYPE 304    |   |
|          |                     | STAINLESS STEEL ASTM A-276 TYPE 316    |   |
| 13       | BOTTOM COVER GASKET | NON ASBESTOS MATERIAL ASTM F104        |   |
| 14       | BOTTOM COVER        | CAST IRON ASTM A-126 CLASS B           |   |
|          |                     | DUCTILE IRON ASTM A-536 (65-45-12)     |   |
| 15       | THRUST COLLAR       | BRONZE BAR ASTM B-505 ALLOY C-93200    |   |
| 16       | GROOVE PIN          | ALLOY STEEL                            |   |
| 17       | CAP SCREW           | CARBON STEEL SAE GRADE 2 (ZINC PLATED) |   |
|          |                     | STAINLESS STEEL TYPE 304               |   |
|          |                     | STAINLESS STEEL TYPE 316               |   |
| 18       | LOCTITE             | GRADE CV                               |   |
| 19       | STUD                | CARBON STEEL AISI B12L14               |   |
| 20       | HEX NUT             | CARBON STEEL SAE GRADE 2 (ZINC PLATED) |   |
| 21       | LOCTITE             | GRADE CV                               |   |
| 22       | BOTTOM COVER CAP    | CAST IRON ASTM A-126 CLASS B           |   |
|          |                     | DUCTILE IRON ASTM A-536 (65-45-12)     |   |
| 23       | O-RING              | RUBBER BUNA-N                          |   |
|          |                     | RUBBER EPDM                            |   |
| 24       | CAP SCREW           | CARBON STEEL SAE GRADE 2 (ZINC PLATED) |   |
|          |                     | STAINLESS STEEL TYPE 304               |   |
|          |                     | STAINLESS STEEL TYPE 316               |   |
| 25       | LOCTITE             | GRADE CV                               |   |
| 26       | BOTTOM STUB SHAFT   | STAINLESS STEEL ASTM A-276 TYPE 304    |   |
|          |                     | STAINLESS STEEL ASTM A-276 TYPE 316    |   |
|          |                     | STAINLESS STEEL ASTM A-564 TYPE 630    |   |
|          |                     | 17-4 PH COND. H-1150                   |   |
| 27       | THRUST BEARING STUD | STAINLESS STEEL TYPE 304               |   |
| 28       | BOTTOM PKG RTNR     | NYLON 101                              |   |
| 29       | PACKING             | RUBBER BUNA-N                          |   |
|          |                     | RUBBER EPDM                            |   |
| 30       | KEY                 | AISI C1045 COLD DRAWN STEEL            |   |
| 31       | CAP SCREW           | STAINLESS STEEL TYPE 304               |   |

|     |         |     |                              |     |
|-----|---------|-----|------------------------------|-----|
| △   | 1-20-14 | AMJ | ADDED SS OPTIONS TO LW & NUT | ES  |
| △   | 7-20-12 | MLB | ADDED EPDM OPTION            | CEM |
| △   | 8-17-07 | CEM | ADDED 17-4 OPTION            | JR  |
| △   | 2-14-06 | CEG | REMOVED SS OPTIONS           | JR  |
| △   | 8-2-05  | ES  | ADDED DUCTILE IRON MATERIAL  | JR  |
| REV | DATE    | BY  | DESCRIPTION                  | APP |

**PRATT** HENRY PRATT COMPANY  
AURORA, ILL.

CROSS SECTION  
PARTS AND MATERIAL LIST  
DOUBLE RUBBER SEAT E-LOK  
BALL VALVE

SCALE NONE DATE 2-04-05  
DRAWN BY AAT CHECKED BY ES  
APPROVED \_\_\_\_\_  
DRWG. NO. GA-11336 REV 5 A/C