

MATERIAL OPTION AS CHECKED

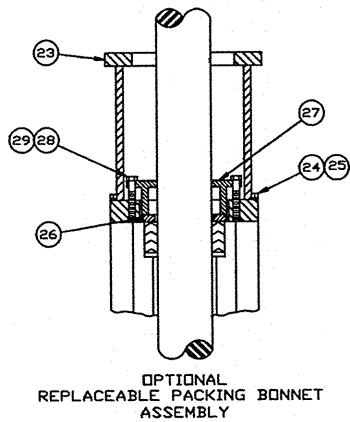

OPTIONAL
REPLACEABLE PACKING BONNET
ASSEMBLY

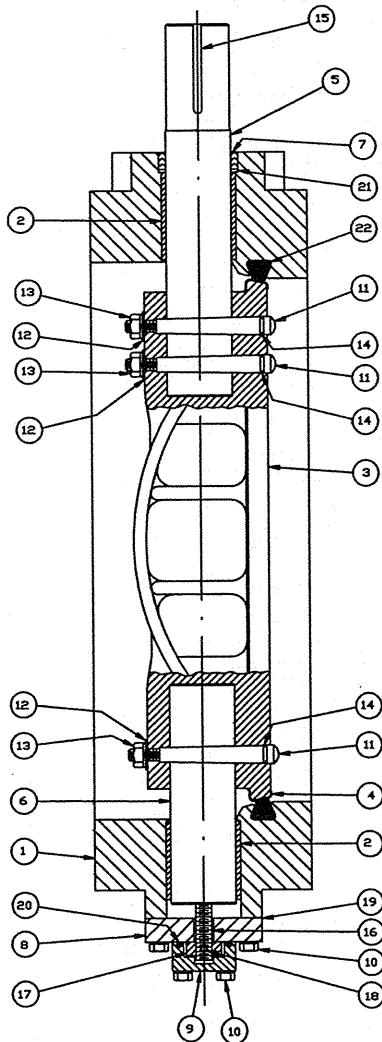

NOTES:

1. CAST IRON IS THE STANDARD BODY MATERIAL FOR VALVES WITH CLASS 150B VALVES.
2. DUCTILE IRON IS THE STANDARD BODY MATERIAL FOR CLASS 250B VALVES AND AN UPGRADE FOR 150B VALVES. DUCTILE IRON IS STANDARD FOR 350B VALVES.
3. SHAFT MATERIAL FOR HP250, HP250 II AND HP350 IS STAINLESS STEEL ASTM A-564 TYPE 630 CONDITION H-1150. THESE VALVES ARE NOT AVAILABLE WITH 304 OR 316 SS.

ITEM NO.	DESCRIPTION	MATERIALS	✓
1	BODY	CAST IRON ASTM A-126 CLASS B DUCTILE IRON ASTM A-536 (65-45-12)	
2	BEARINGS	TEFLON LINED, FIBERGLASS BACKED	
3	DISC	CAST IRON ASTM A-48 CLASS 40 DUCTILE IRON ASTM A-536 (65-45-12)	
4	DISC EDGE	STAINLESS STEEL TYPE 316	
5	TOP STUB SHAFT	STAINLESS STEEL ASTM A-276 TYPE 304 STAINLESS STEEL ASTM A-276 TYPE 316 STAINLESS STEEL ASTM A-564 TYPE 630 COND. H-1150	
6	BOTTOM STUB SHAFT	STAINLESS STEEL ASTM A-276 TYPE 304 STAINLESS STEEL ASTM A-276 TYPE 316 STAINLESS STEEL ASTM A-564 TYPE 630 COND. H-1150	
7	PACKING	RUBBER (BUNA-N) RUBBER (EPDM)	
8	BOTTOM COVER	CAST IRON ASTM A-126 CLASS B DUCTILE IRON ASTM A-536 (65-45-12)	
9	BOTTOM COVER CAP	CAST IRON ASTM A-126 CLASS B DUCTILE IRON ASTM A-536 (65-45-12)	
10	CAP SCREWS	CARBON STEEL STAINLESS STEEL TYPE 304 STAINLESS STEEL TYPE 316	
11	TAPER PINS	STAINLESS STEEL ASTM A-564 TYPE 630 COND. H-1150	
12	LOCKWASHERS	STAINLESS STEEL TYPE 304 STAINLESS STEEL TYPE 316	
13	HEX NUTS	STAINLESS STEEL TYPE 304 STAINLESS STEEL TYPE 316	
14	O-RINGS	RUBBER BUNA-N RUBBER (EPDM)	
15	KEY	CARBON STEEL AISI 1045 STAINLESS STEEL TYPE 304	
16	THRUST BEARING STUD	STAINLESS STEEL TYPE 316 STAINLESS STEEL ASTM A-564 TYPE 630 COND. H-1150	
17	THRUST COLLAR	BRONZE ASTM B-505 ALLOY C93200	
18	GROOVE PIN	ALLOY STEEL	
19	BOTTOM COVER GASKET	NON ASBESTOS MATERIAL ASTM F104	
20	O-RING	RUBBER BUNA-N RUBBER (EPDM)	
21	PACKING RETAINER	NYLON FOR 150 VALVES BRONZE ASTM B-505/B-584 C93200 FOR 250&350 VALVES	
22	RUBBER SEAT	RESILOSEAL R (BUNA-N) RESILOSEAL Z (EPDM)	
23	BONNET	CAST IRON ASTM A-48 CLASS 40 CARBON STEEL PLATES ASTM A-36	
24	LOCKWASHERS	CARBON STEEL	
25	CAP SCREWS	ALLOY STEEL SAE GR 8	
26	PACKING GLAND	BRONZE SAE 660	
27	FOLLOWER	BRONZE ASTM B-584 ALLOY C93200 BRONZE ASTM B-584 ALLOY C87500	
28	CAP SCREWS	CARBON STEEL SAE GR 2	
29	LOCKWASHER	CARBON STEEL	

REV	DATE	BY	DESCRIPTION	APP.
△	6/22/17	LF	UPDATED PACKING RETAINER MATERIAL	JL
△	7/15/11	JTC	UPDATED MATERIAL	RCB
△	6/8/11	MEM	ADDED ASTM A-36 OPTION	SS
△	1/15/10	JMR	REMOVED 24" FROM TITLE	CEM
△	9-25-09	CEM	CORRECT NOTES, ADD HP350	JR
△	2-2-09	CEM	REMOVED CI ASTM A-48 OPTION	JR
△	9-1-06	CEG	REMOVED 304 & 316 OPTION	JR
△	8-22-06	CEG	ADD II OPTION FOR BOT COVER & CAP	JR

PRATT HENRY PRATT COMPANY
AURORA, ILL.

CROSS SECTION
30" & UP TRITON-XR & HP250 II
30" & UP HP250 & HP350
BUTTERFLY VALVE

SCALE NONE DATE 2-04-05

DRAWN BY AAT CHECKED BY ES

APPROVED GA=BORDER

DRWG. NO. GA-11338 REV 8 1/2