

VALVE SIZE	A	B	C	CC	D	DD	E	EE	F	FF	G	GG	X
6	6-1/2	5-1/8	11	11	6-3/4	4-1/4	1-1/16	1-1/16	8--3/4	6--3/4	9-1/2	9-1/2	4-1/4
8	7-3/4	6-1/2	13-1/2	13-1/4	7-5/16	4-5/16	1-1/8	1-1/8	8--3/4	6--3/4	11-3/4	11-3/4	4-13/16
10	9	9-7/8	16	15-9/16	9	5	1-1/4	1-3/16	12--7/8	8--3/4	14-1/4	14	6-1/2
12	10-1/2	11-3/8	19	17-15/16	9-1/4	5-1/4	1-1/4	1-1/4	12--7/8	8--3/4	17	16-1/4	6-3/4
14	11-7/8	12-3/4	21	20-5/16	9-3/4	5-3/4	1-3/8	1-5/16	12--1	10--3/4	18-3/4	18-3/4	6-1/4
16	13-1/2	14-3/8	23-1/2	22-9/16	10	6	1-7/16	1-3/8	16--1	12--3/4	21-1/4	21	6-1/2
18	14-3/8	15-1/4	25	24-11/16	10-1/8	6-1/8	1-9/16	1-7/16	16--1-1/8	12--3/4	22-3/4	23-1/4	6-5/8
20	16	16-7/8	27-1/2	27-3/32	10-1/4	6-1/4	1-11/16	1-1/2	20--1-1/8	14--3/4	25	25-1/2	6-3/4

ACTUATOR SIZE	J	L	M	N	P	Q	R	NUMBER OF TURNS
MDT-2S	4-11/16	2	2-1/8	2	4-1/2	4-1/2	8-1/4	32
MDT-3S	5-5/8	2-7/16	3-1/4	3-5/32	5-5/8	5-3/8	10-3/8	30
MDT-4S	6-3/8	2-27/32	3-3/8	4	7-5/16	6-3/4	11-5/16	40
MDT-5	7-9/16	3-15/32	4-1/2	5-1/2	8-3/4	10	17	44

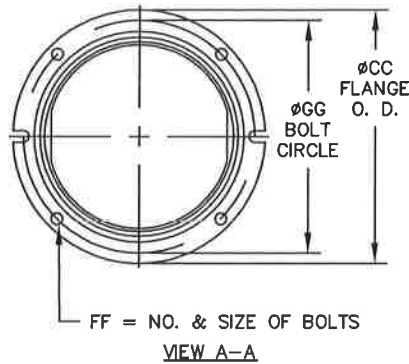
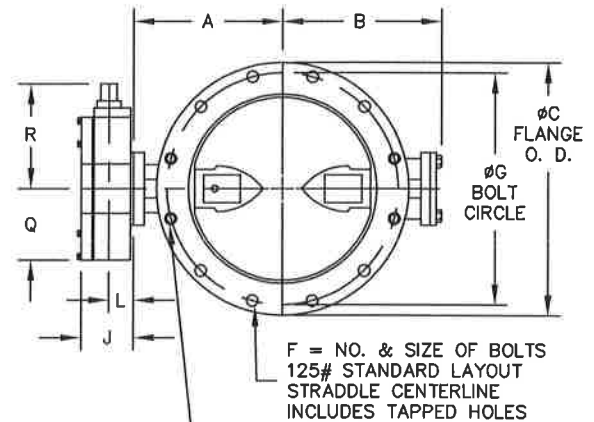
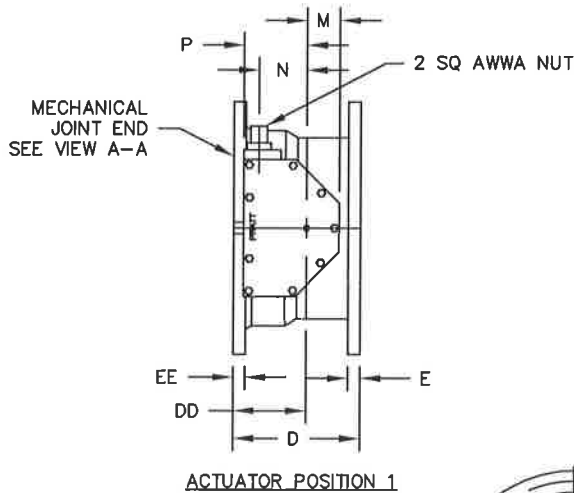

CAST STEEL BODIES 4" THRU 8" & CAST IRON BODIES 18" & 20" HAVE 4 TAPPED HOLES "F" SIZE UNC-2B X "E" DEEP PER FLANGE. 2 HOLES AT TOP AND 2 HOLES AT BOTTOM

NOTES:

- ALL DIMENSIONS SHOWN IN INCHES.
- "D" DIMENSION $\pm 1/16$ " FOR 6" THRU 10" VALVES.
"D" DIMENSION $\pm 1/8$ " FOR 12" THRU 20" VALVES.
- FOR BOLTS SMALLER THAN $\phi 1-3/4$, BOLT HOLES WILL BE $1/8$ " LARGER THAN DIAMETER OF BOLT.
FOR BOLTS $\phi 1-3/4$ OR LARGER, BOLT HOLES WILL BE $1/4$ " LARGER THAN DIAMETER OF BOLT.
- DIMENSIONS AND DRILLING OF END FLANGE CONFORM TO THE AMERICAN CAST IRON FLANGE STANDARDS, CLASS 125 (B16.1).
- DIMENSIONS AND DRILLING OF MECHANICAL JOINT END CONFORM TO ANSI/ AWWA C111/ A21.11.
- VALVES MANUFACTURED & TESTED IN ACCORDANCE WITH AWWA SPECIFICATION C-504 LATEST REVISION, CLASS 150B.
- RECOMMENDATION FOR MATING FLANGES: WHERE INSULATING BUSHINGS ARE USED, IT IS NECESSARY THAT BOLT HOLES BE DRILLED OVERSIZE BY AN AMOUNT EQUAL TO TWO TIMES THE INSULATING SLEEVE THICKNESS TO MAINTAIN THE SAME MINIMUM CLEARANCE FOR BOLTS.

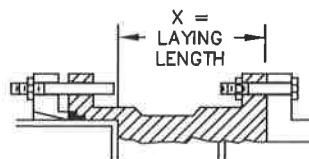

INSTALLATION DIAGRAM
BOLTS, NUTS, GLANDS
AND GASKETS FURNISHED
BY OTHERS

REV	DATE	BY	DESCRIPTION	APP.
1	2/10/17	JUR	FIXED 10/12 D.DD.X	JwD
PLATT				
6"-20" GROUNDHOG VALVE FLANGE X MECHANICAL JOINT ENDS MDT BURIED SERVICE NUT				
SCALE		NONE		DATE
				5-18-05
DRAWN BY		ES		CHECKED BY
				RCB
APPROVED		GA-BORDER		
DRWG. NO.	GA-11425	REV	1	A/C