

MATERIAL OPTIONS AS CHECKED

ITEM NO.	DESCRIPTION	MATERIALS	✓
1	BODY	CAST IRON ASTM A-48 CLASS 40 (MKII ONLY)	
		CAST IRON ASTM A-126 CLASS B *	
		DUCTILE IRON ASTM A-536 (65-45-12)	
2	DISC	CAST IRON ASTM A-126 CLASS B STAINLESS STEEL EDGE TYPE 316 (DUCTILE IRON MAY BE SUBSTITUTED)	
		DUCTILE IRON ASTM A-536 (65-45-12) STAINLESS STEEL EDGE TYPE 316	
		STAINLESS STEEL ASTM A-351 GRADE CF8M	
3	SHAFT	STAINLESS STEEL ASTM A-276 TYPE 304	
		STAINLESS STEEL ASTM A-276 TYPE 316	
		STN. STL. A-564 TYPE 630 COND. H-1150	
4	SQUEEZE PIN	STAINLESS STEEL ASTM A-276 TYPE 304	
		STAINLESS STEEL ASTM A-276 TYPE 316	
		STN. STL. A-564 TYPE 630 COND. H-1150	
5	BEARING	NYLATRON GS	
		RULON LR (HIGH TEMPERATURE ONLY)	
		FLUOMETAL (PIFE IMPREGNATED w/ EXPANDED 317L METAL SHEET)	
6	PACKING	RUBBER BUNA-N	
		RUBBER (EPDM)	
7	KEY	AISI C1045 COLD DRAWN STEEL	
8	COVER	CAST IRON ASTM A-48 CLASS 40	
		CAST IRON ASTM A-126 CLASS B	
		DUCTILE IRON ASTM A-536 (65-45-12)	
9	LOCKWASHER	STAINLESS STEEL TYPE 304	
		STAINLESS STEEL TYPE 316	
10	CAP SCREW	STAINLESS STEEL TYPE 304	
		STAINLESS STEEL TYPE 316	
11	EXP. PLUG	STAINLESS STEEL TYPE 304	
		STAINLESS STEEL TYPE 316	
12	SEAT	RUBBER BUNA-N	
		RUBBER (EPDM)	
13	BONNET	CAST IRON ASTM A-48 CLASS 40 FOR 3"-10" & 12" W/ MDT2S	
		DUCTILE IRON ASTM A-536 65-45-12 FOR 10" W/ MDT3S & 12" -20"	
14	CAP SCREW	ALLOY STEEL SAE GRADE 8	
15	LOCKWASHER	STAINLESS STEEL TYPE 304	
16	THD. STUD	STAINLESS STEEL TYPE 304	
17	HEX NUT	STAINLESS STEEL TYPE 304	
18	GLAND	BRONZE ASTM B-584 ALLOY C86400	
19	LINING	EPOXY	
		RUBBER (SAME AS 12)	

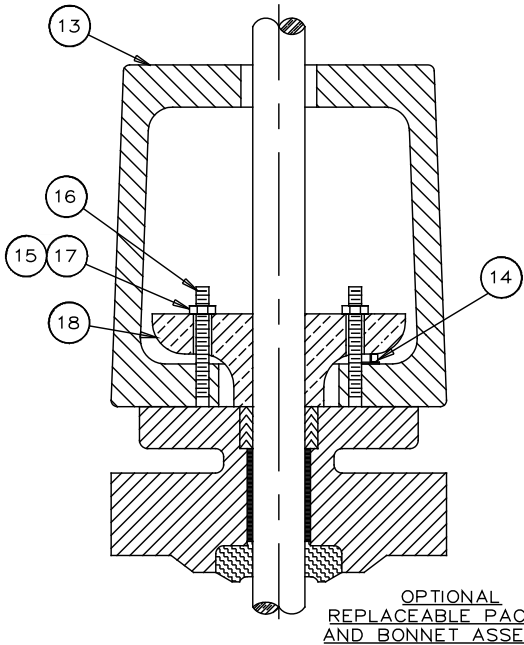

* DUCTILE IRON MAY BE SUBSTITUTED FOR 3" & 4" BODIES

10/19/17	JUR	UPDATED TITLE BLOCK	SS
01/18/16	JCL	ADDED DI COVER OPTION	RF
5/28/14	DSL	UPDATED TITLE BLOCK	SJS
REV	DATE	BY	DESCRIPTION

PRATT	
CROSS SECTION PARTS AND MATERIALS LIST 3"-20" BONDED SEAT VALVES 150B & 250B	
SCALE	NONE
DATE	10-27-05
DRAWN BY	ES
CHECKED BY	RCB
APPROVED	GA=BORDER
DRWG. NO.	GA-11486
REV	12
	A/C