

A. CHECK WITH FACTORY WHEN SELECTING ALTERNATE MIRROR ACTUATOR STYLES.

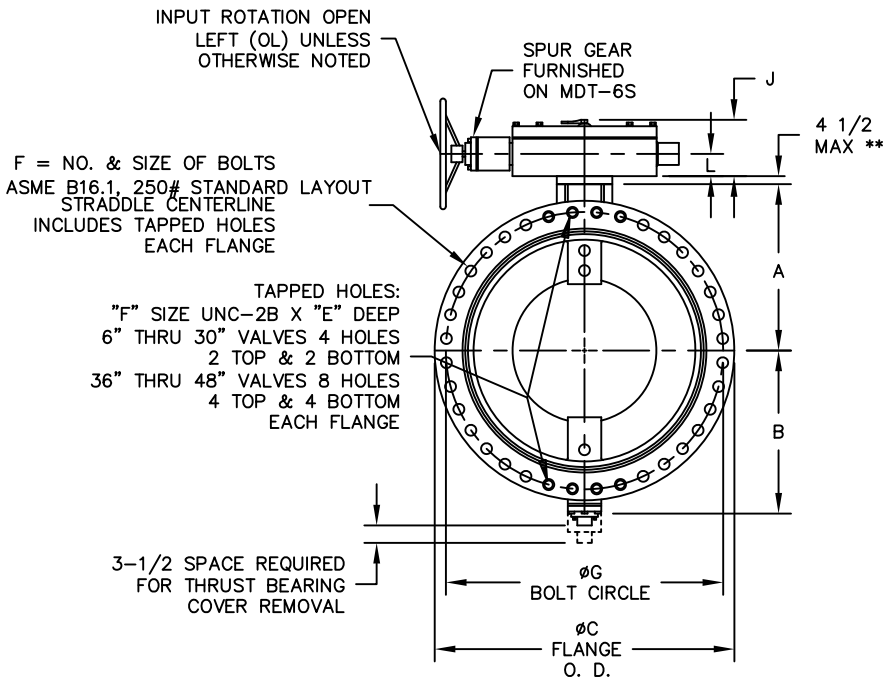

NOTES:

1. ALL DIMENSIONS SHOWN IN INCHES.
2. "D" DIMENSION $\pm 1/8$ ".
3. FOR BOLTS SMALLER THAN $\phi 1-3/4$, BOLT HOLES WILL BE $1/8$ " LARGER THAN DIAMETER OF BOLT. FOR BOLTS $\phi 1-3/4$ OR LARGER, BOLT HOLES WILL BE $1/4$ " LARGER THAN DIAMETER OF BOLT.
4. RECOMMENDATION FOR MATING FLANGES: WHERE INSULATING BUSHINGS ARE USED, IT IS NECESSARY THAT BOLT HOLES BE DRILLED OVERSIZE BY AN AMOUNT EQUAL TO TWO TIMES THE INSULATING SLEEVE THICKNESS TO MAINTAIN THE SAME MINIMUM CLEARANCE FOR BOLTS.
5. CAUTION: IT IS RECOMMENDED THAT VALVES BE INSTALLED INTO THE PIPING SYSTEM IN ACCORDANCE WITH AWWA M-11 IN ORDER TO PREVENT ANY UNDUE PIPING STRESS, DEFLECTION OR BENDING THAT MAY EFFECT THE PERFORMANCE OF THE VALVE.

ACTUATOR SIZE	J	L	M	N	P	Q	R	S	T	V	W	NUMBER OF TURNS
MDT-2S	4-11/16	2	2-1/8	2	4-1/2	$\Delta 4-1/4$	8-1/4	7-7/8	7-7/8	8	9-1/8	32
MDT-3S	5-5/8	2-7/16	3-1/4	3-5/32	5-5/8	5-3/8	10-3/8	10-1/2	10-1/8	12	9-1/8	30
MDT-4S	6-3/8	2-27/32	3-3/8	4	7-5/16	6-3/4	11-5/16	11-1/2	11	18	9-1/8	40
MDT-5	7-9/16	3-15/32	4-1/2	5-1/2	8-3/4	$\Delta 10-7/16$	17	17 3/16	17-3/16	24	16-7/16	44
MDT-5S	8-5/16	3-15/16	5-1/2	7	10-1/2	15-15/16	19-7/8	20	19-13/16	24	22-1/4	136
MDT-6S	10-3/16	5-1/16	7	8-1/4	12-5/8	14-3/16	26-1/2	27-3/4	27-1/2	24	22-1/4	215

VALVE SIZE	A	B	C	D	E	F	G
6	7-1/4	8-3/8	12-1/2	6	$\Delta 1-1/2$	12--3/4	10-5/8
8	8-1/2	9-5/8	15	8	1-5/8	12--7/8	13
10	9-3/4	11	17-1/2	8	1-7/8	16--1	15-1/4
12	11-1/2	12-5/8	20-1/2	8	2	16--1-1/8	17-3/4
14	12-3/4	13-7/8	23	12	2-1/8	20--1-1/8	20-1/4
16	14	15-1/8	25-1/2	12	2-1/4	20--1-1/4	22-1/2
18	15-1/4	16-3/8	28	12	2-3/8	24--1-1/4	24-3/4
20	17	17-5/8	30-1/2	12	2-1/2	24--1-1/4	27
24	19-3/4	20-1/4	36	12	2-3/4	24--1-1/2	32
30	25-5/8	26	43	12	3	28--1-3/4	39-1/4
36	28-1/8	31-1/8	50	15	3-3/8	32--2	46
42	32-1/8	35-1/8	57	15	3-11/16	36--2	52-3/4
48	36-1/4	39-5/8	65	15	4	40--2	60-3/4

FLANGE THICKNESS "E" TOLERANCES	
3" THRU 12"	+1/8" - 0"
14" THRU 24"	+3/16" - 0"
30" THRU 48"	+1/4" - 0"

REV	DATE	DESCRIPTION	DWN	APP
8	5/1/23	ADDED POSITION CHART	RTF	RF
7	09/17/21	REMOVE NOTE FOR RECOMMENDED FLOW DIRECTION FOR HP350	CA	TF
6	9/12/16	REVISED FLOW DIRECTION NOTE AND HW SIZES FOR MDT4S/5	SAD	SS
5	8/28/14	REV. DIM/ADDED TOL. BLOCK	JUR	RCB
4	01/28/10	4-1/4 WAS 4-1/2; 10-7/16 WAS 10	MZ	CEM
3	11/17/09	CORRECT FLOW	CEM	JR
2	11/13/09	REMOVED NOTE	DSL	CEM
1	1/19/09	ADDED DIMENSION	AA	JW

PRATT
a MUELLER brand

GENERAL ARRANGEMENT DRAWING
6"-48" HP-350 VALVE FLANGED ENDS
MDT MANUAL ACTUATOR

SCALE NONE DATE 1-05-08

DRAWN BY AA CHECKED BY PPS

APPROVED _____ | **GA=BORDER**

DRWG. NO. GA-11862 REV 8 $\frac{A}{C}$