

ACTUATOR SIZE	J	L	M	N	P	Q	R	S	T	V	W	NUMBER OF TURNS
MDT-3S	5-5/8	2-7/16	3-1/4	3-5/32	5-5/8	5-3/8	10-3/8	10-1/2	10-1/8	12	9-1/8	30
MDT-4S	6-3/8	2-27/32	3-3/8	4	7-5/16	6-3/4	11-5/16	11-1/2	11	12	9-1/8	40
MDT-5	7-9/16	3-15/32	4-1/2	5-1/2	8-3/4	10	17	17 3/16	17-3/16	18	16-7/16	44
MDT-5S	8-5/16	3-15/16	5-1/2	7	10-1/2	15-15/16	19-7/8	20	19-13/16	24	22-1/4	136
MDT-6S	10-3/16	5-1/16	7	8-1/4	12-5/8	14-3/16	26-1/2	27-3/4	27-1/2	24	22-1/4	215

VALVE SIZE	150 PSI						
	A	B	C	D	E	F	G
24	18-5/8	18-3/8	32	8	1-7/8	20--1-1/4	29-1/2
30	21-1/2	24-3/8	38-3/4	12	2-1/8	28--1-1/4	36
36	25-7/16	28-1/4	46	12	2-7/16	32--1-1/2	42-3/4
42	29-7/8	32-11/16	53	12	2-5/8	36--1-1/2	49-1/2
48	34-1/16	36-7/8	59-1/2	15	2-3/4	44--1-1/2	56
54	37-1/2	40-11/16	66-1/4	15	3	44--1-3/4	62-3/4
60	41-3/4	45-3/16	73	15	3-1/8	52--1-3/4	69-1/4
66	46-1/16	49-1/2	80	18	3-3/8	52--1-3/4	76
72	50	53-1/8	86-1/2	18	3-1/2	60--1-3/4	82-1/2

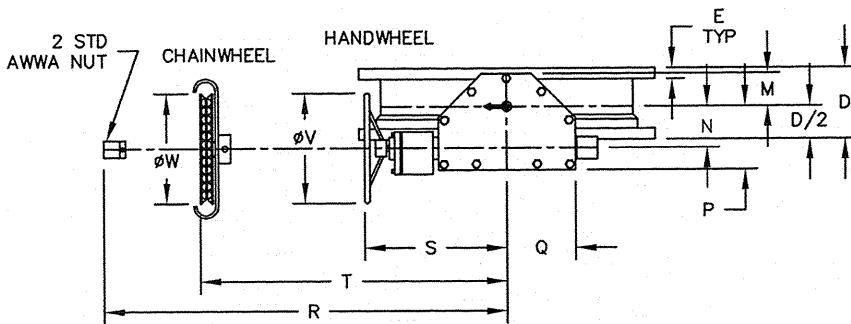

ACTUATOR POSITION 1

NOTES:

1. ALL DIMENSIONS SHOWN IN INCHES.
2. "D" DIMENSION $\pm 1/8"$.
3. FOR BOLTS SMALLER THAN $\phi 1-3/4$, BOLT HOLES WILL BE $1/8"$ LARGER THAN DIAMETER OF BOLT. FOR BOLTS $\phi 1-3/4$ OR LARGER, BOLT HOLES WILL BE $1/4"$ LARGER THAN DIAMETER OF BOLT.
4. DIMENSIONS AND DRILLING OF END FLANGES CONFORM TO THE AMERICAN CAST IRON FLANGE STANDARDS, CLASS 125 (B16.1).
5. VALVES MANUFACTURED & TESTED IN ACCORDANCE WITH AWWA SPECIFICATION C-504 LATEST REVISION, CLASS 150B.
6. RECOMMENDATION FOR MATING FLANGES: WHERE INSULATING BUSHINGS ARE USED, IT IS NECESSARY THAT BOLT HOLES BE DRILLED OVERSIZE BY AN AMOUNT EQUAL TO TWO TIMES THE INSULATING SLEEVE THICKNESS TO MAINTAIN THE SAME MINIMUM CLEARANCE FOR BOLTS.
7. CAUTION: IT IS RECOMMENDED THAT VALVES BE INSTALLED INTO PIPING SYSTEM IN ACCORDANCE WITH AWWA M-11 TO PREVENT ANY UNDUE PIPING STRESS, DEFLECTION OR BENDING THAT MAY AFFECT THE PERFORMANCE OF THE VALVE.

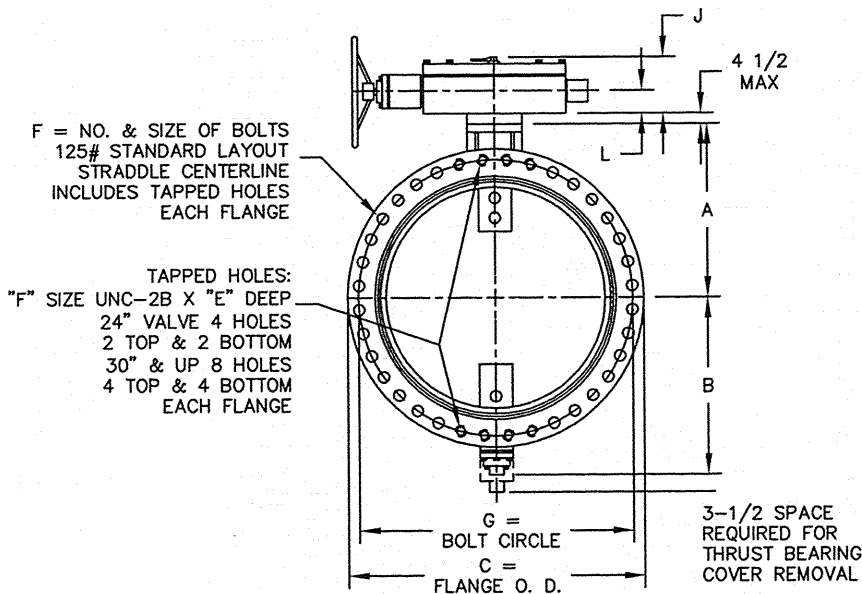

TOLERANCES

FLANGE THICKNESS "E":	$+1/4"$ 0
LAYING LENGTH "D":	
24" THRU 72"	$\pm 1/8"$
BOLT CIRCLE "G":	$+1/16"$
FLANGE O.D. "C":	
24" THRU 48"	$+3/16"$
54" THRU 72"	$+1/4"$

3	07/18/17	UPDATED TITLE BLOCK/LOGO	JWD	ZF
2	04/29/11	ADD TOL, REVISED DIM	JLM	RCB
1	03/12/10	REMOVED 25 & 75 LB.	MZ	CEM
REV	DATE	DESCRIPTION	DWN	APP

PRATT

GENERAL ARRANGEMENT DRAWING
24" - 72" XR70 FLG BFV
MDT MANUAL ACTUATOR

SCALE	NONE	DATE	1-20-09
DRAWN BY	CEM	CHECKED BY	JR
APPROVED		GA=BORDER	
DRWG. NO.	GA-11863	REV	3