

ACTUATOR POSITION 1

TOLERANCES	
FLANGE THICKNESS "E":	+1/4"
LAYING LENGTH "D":	
24" THRU 72"	+1/8"
BOLT CIRCLE "G":	+1/16"
FLANGE O.D."C":	
24" THRU 48"	+3/16"
54" THRU 72"	+1/4"

NOTES:

- ALL DIMENSIONS SHOWN IN INCHES.
- "D" DIMENSION ±1/8" FOR 24" AND LARGER VALVES.
- FOR BOLTS SMALLER THAN ∅1-3/4, BOLT HOLES WILL BE 1/8" LARGER THAN DIAMETER OF BOLT. FOR BOLTS ∅1-3/4 OR LARGER, BOLT HOLES WILL BE 1/4" LARGER THAN DIAMETER OF BOLT.
- DIMENSIONS AND DRILLING OF END FLANGES CONFORM TO THE AMERICAN CAST IRON FLANGE STANDARDS, CLASS 125 (B16.1).
- VALVES MANUFACTURED & TESTED IN ACCORDANCE WITH AWWA SPECIFICATION C-504 LATEST REVISION, CLASS 250B.
- RECOMMENDATION FOR MATING FLANGES: WHERE INSULATING BUSHINGS ARE USED, IT IS NECESSARY THAT BOLT HOLES BE DRILLED OVERSIZE BY AN AMOUNT EQUAL TO TWO TIMES THE INSULATING SLEEVE THICKNESS TO MAINTAIN THE SAME MINIMUM CLEARANCE FOR BOLTS.
- CAUTION: IT IS RECOMMENDED THAT VALVES BE INSTALLED INTO PIPING SYSTEM IN ACCORDANCE WITH AWWA M-11 TO PREVENT ANY UNDUE PIPING STRESS, DEFLECTION OR BENDING THAT MAY AFFECT THE PERFORMANCE OF THE VALVE.
- EXTENSION STEM CAN BE USED WITH STANDARD VALVE BOXES OR 5" SOIL PIPE

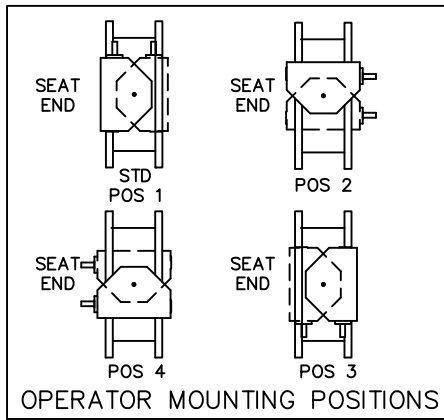
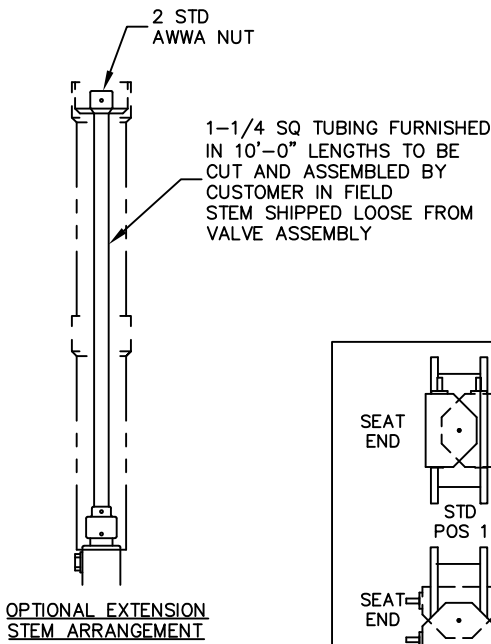

A. CHECK WITH FACTORY WHEN SELECTING ALTERNATE MIRROR ACTUATOR STYLES.

VALVE SIZE	A	B	C	D	E	F	G
24	18-5/8	18-3/8	32	8	1-7/8	20/1-1/4	29-1/2
30	21-1/2	24-1/8	38-3/4	12	2-1/8	28/1-1/4	36
36	25-7/16	28-1/4	46	12	2-7/16	32/1-1/2	42-3/4
42	29-7/8	32-11/16	53	12	2-5/8	36/1-1/2	49-1/2
48	34-1/16	36-7/8	59-1/2	15	2-3/4	44/1-1/2	56
54	37-1/2	40-9/16	66-1/4	15	3	44/1-3/4	62-3/4
60	41-3/4	44-13/16	73	15	3-1/8	52/1-3/4	69-1/4
66	46-1/16	49-1/8	80	18	3-7/16	52/1-3/4	76
72	50	53-1/16	86-1/2	18	3-1/2	60/1-3/4	82-1/2

ACTUATOR SIZE	J	L	M	N	P	Q	R	NUMBER OF TURNS
MDT-5	7-9/16	3-15/32	4-1/2	5-1/2	8-3/4	10	17	44
MDT-5S	8-5/16	3-15/16	5-1/2	3-5/8	10-1/2	15-15/16	19-7/8	136
MDT-6S	10-3/16	5-1/16	7	8-1/4	12-5/8	14-3/16	26-1/2	215

REV	DATE	DESCRIPTION	DWN	APP
5	5/2/23	ADDED POSITION CHART	RTF	RF
4	12/15/16	REVISED MDT-6S "J" REVISED MDT-5S "N"	JWD	RF
3	4/26/10	RE. COLUMN "B", ADD TOL.	JLM	RCB
2	12/11/10	ADDED SIZES	CEM	JR
1	10/06/08	36E WAS 2-3/8	SK	RCB

PRATT

HP250II ANSI 125# FLG
 24" THRU 72"
 MDT BURIED SERVICE ACTUATOR

SCALE NONE DATE 1/30/09
 DRAWN BY CEM CHECKED BY JR
 APPROVED GA=BORDER
 DRWG. NO. GA-11867 REV 5 A/C