

PIPE SIZE	PIPE O. D.	MIN. MATING I. D.
4	4.80	3.00
6	6.90	5.59
8	9.05	7.55
10	11.10	9.83
12	13.20	11.60
14	15.65	12.81
16	17.80	14.81
18	19.92	16.85
20	22.06	18.86

ACTUATOR SIZE	VALVE SIZE	J	L	M	N	P	Q	R	NUMBER OF TURNS
MDT-2S	3"-8"	4-11/16	2	2-1/8	2	4-1/2	4-1/4	8-1/4	32
MDT-3S	8"-14"	5-5/8	2-7/16	3-1/4	3-5/32	5-5/8	5-3/8	10-3/8	30
MDT-4S	16" & 18"	6-3/8	2-27/32	3-3/8	4	7-5/16	6-3/4	11-5/16	40
MDT-5	18" & 20"	7-9/16	3-15/32	4-1/2	5-1/2	8-3/4	10	17	44

VALVE SIZE	A	B	C	D	E	F	G	X
4	5-1/2	3-1/2	9	8-1/8	1	4--3/4	7 1/2	3-1/8
6	6-1/2	5-1/8	11	8-1/2	1	6--3/4	9 1/2	3-1/2
8	7-3/4	6-1/2	13-1/4	8-5/8	1-1/8	6--3/4	11 3/4	3-5/8
10	9	9-7/8	15-9/16	10	1-3/16	8--3/4	14	5
12	10-1/2	11-3/8	17-15/16	10-1/2	1-1/4	8--3/4	16-1/4	5-1/2
14	11-7/8	12-3/4	20-5/16	11-1/2	1-5/16	10--3/4	18 3/4	4-1/2
16	13-1/2	14-3/8	22-9/16	12	1-3/8	12--3/4	21	5
18	14-3/8	15-1/4	24-11/16	12-1/4	1-3/8	12--3/4	23-1/4	5-1/4
20	16	16-7/8	27-3/32	12-1/2	1-1/2	14--3/4	25-1/2	5-1/2

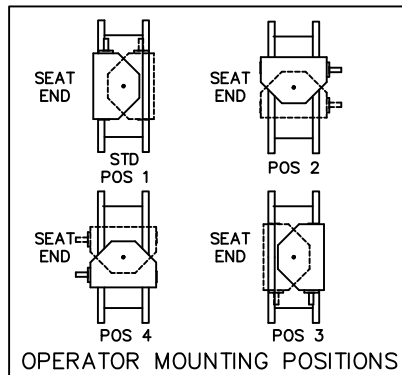
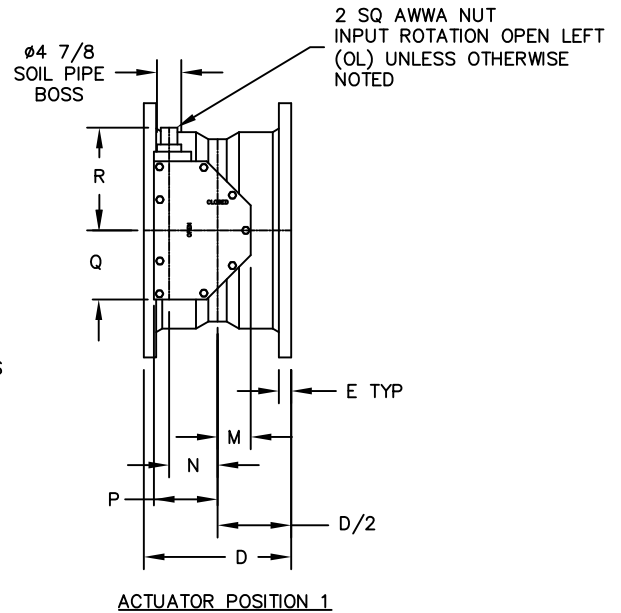
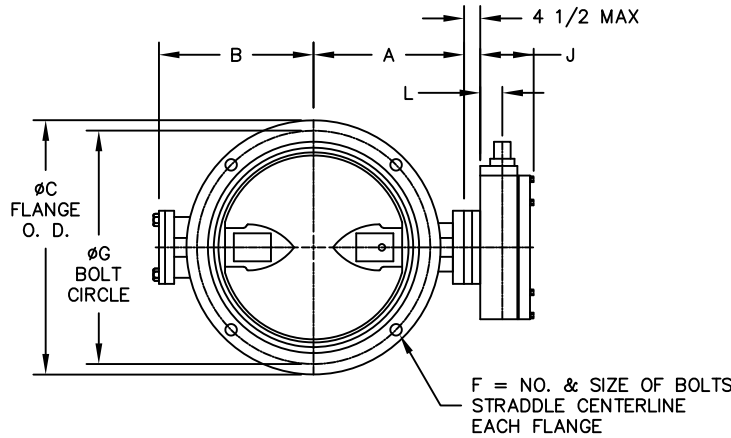

NOTES:

1. ALL DIMENSIONS SHOWN IN INCHES.
2. "D" DIMENSION  $\pm 1/16$ " FOR 4" VALVES. "D" DIMENSION  $+1/8$ "  $-0$  FOR 6" THRU 20" VALVES.
3. BOLT HOLES WILL BE  $1/8$ " LARGER THAN DIAMETER OF BOLT.
4. DIMENSIONS AND DRILLING OF MECHANICAL JOINT ENDS CONFORM TO ANSI/ AWWA C111/ A21.11.
5. VALVES MANUFACTURED & TESTED IN ACCORDANCE WITH AWWA SPECIFICATION C-504 LATEST REVISION, CLASS 250B.
6. EXTENSION STEM CAN BE USED WITH STANDARD VALVE BOXES OR 5" SOIL PIPE
7. CAUTION: WHEN USING 10" AND 12" VALVES ON CLASS 200 PVC PIPE, PIPE END I.D. MUST BE BEVELLED TO ENSURE CLEARANCE FOR DISC AND PROPER VALVE OPERATION.

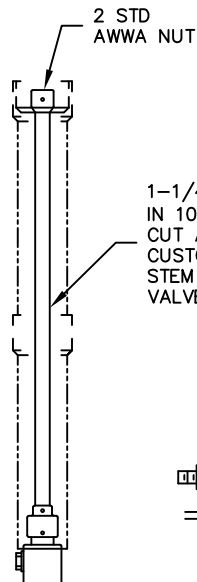

- A. IGNORE SEAT SIDE DESIGNATION ON BFV SIZE 3" -20"
- B. CHECK WITH FACTORY WHEN SELECTING ALTERNATE MIRROR ACTUATOR STYLES.

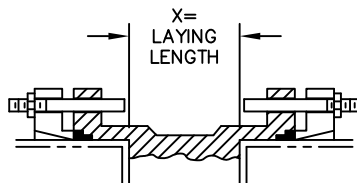

OPTIONAL EXTENSION STEM ARRANGEMENT

INSTALLATION DIAGRAM  
BOLTS, NUTS, GLANDS  
AND GASKETS FURNISHED  
BY OTHERS

REV	DATE	DESCRIPTION	DWN	APP
4	5/2/23	ADDED POSITION CHART	RTF	RF
3	01/13/17	REM SLOTS FROM PICTURE	JWD	RF

**PRATT**

HP250II MJE  
4" THRU 20"  
MDT BURIED SERVICE ACTUATOR

SCALE	NONE	DATE	2/2/09
DRAWN BY	CEM	CHECKED BY	JMR
APPROVED	GA=BORDER		
DRWG. NO.	GA-11872	REV	4