

VALVE SIZE	ORFICE SIZE	MAX C.W.P.	W	H	HC	PRATT PN	WT (LBS)	OUTLET SIZE
1"	3/16"	150	7"	9-15/16"	10-13/16"	WAR10-316-150-FS	23.2	1/2"
1"	5/32"	300	7"	9-15/16"	10-13/16"	WAR10-532-300-FS	23.2	1/2"
2"	3/16"	150	7"	9-15/16"	10-13/16"	WAR20-316-150-FS	23.2	1/2"
2"	5/32"	300	7"	9-15/16"	10-13/16"	WAR20-532-300-FS	23.2	1/2"
2"	23/64"	150	9-1/2"	12-1/4"	13-11/32"	WAR20-2364-150-FS	48.1	1"
2"	7/32"	300	9-1/2"	12-1/4"	13-11/32"	WAR20-732-300-FS	48.1	1"
3"	23/64"	150	9-1/2"	12-1/4"	13-11/32"	WAR30-2364-150-FS	48.1	1"
3"	7/32"	300	9-1/2"	12-1/4"	13-11/32"	WAR30-732-300-FS	48.1	1"

ITEM	DESCRIPTION	MATERIAL
1	BODY	DUCTILE IRON ASTM A536 65-45-12
2	COVER	DUCTILE IRON ASTM A536 65-45-12
3	LEVER BRACKET	316SS
4	SEAT	316SS
5	FLOAT	316SS
6	O-RING	EPDM
7	COVER BOLT	316SS
8	SHORT LEVER ARM	316SS
9	BUTTON	EPDM/SS
10	PIVOT PIN/RET RING	316SS/17-7 PH SS
11	FLOAT RETAINER	316SS
12	POSITIONER	316SS
13	LOCK WASHER	316SS
14	LOCK NUT	316SS
15	1/2" PIPE PLUG	316SS
16	LONG LEVER ARM	316SS
17	ARM LINK	316SS
18	POSITIONING PIN	420SS
19	LOCK WASHER	316SS
20	CLEVIS	316SS
21	VENT AND CAP SCREEN	DUCTILE IRON ASTM A536/ SCREEN 316SS

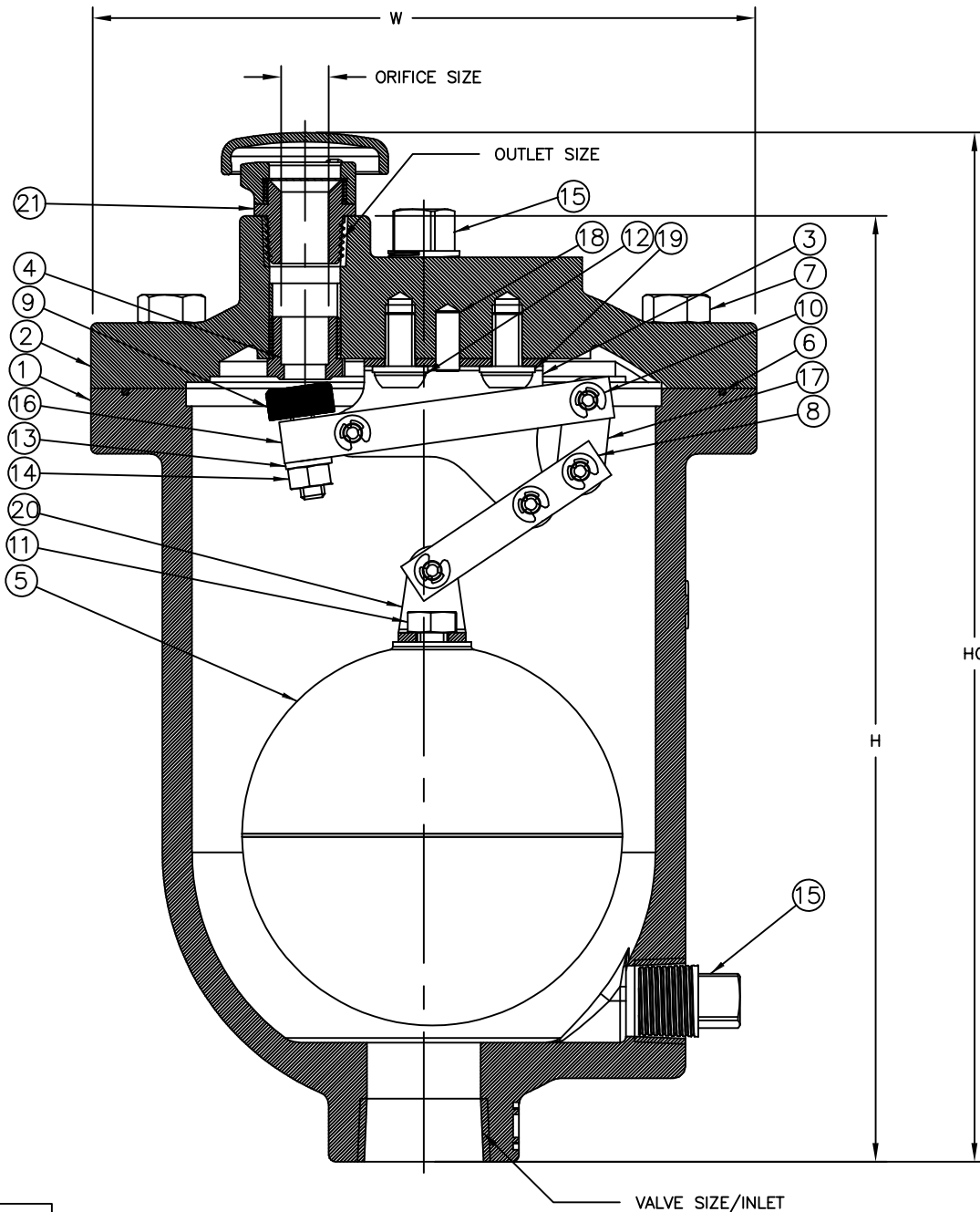

2	2/22/18	UPDATED P/N'S/MATERIALS	JUR	SS
1	8/17/17	ADDED DIM PER CATALOG	SJS	SS
REV	DATE	DESCRIPTION	DWN	APP

PRATT

1"-3" WAR COMPOUND LEVER
WATER AIR RELEASE VALVE

SCALE NONE DATE 4/2/14

DRAWN BY JUR CHECKED BY RCB

APPROVED GA-BORDER

DRWG. NO. GA-11916 REV 2 A/C