

VALVE SIZE	OUTLET SIZE	ORIFICE SIZE	MAX C.W.P	INLET CONNECTION	W	H	PRATT PN	WT. LBS
2"	1"	1/8"	150	NPT	7"	14-15/16"	WWCV20-018-150-FS	40.57
2"	2"	9/64"	150	NPT	9-1/2"	18-1/16"	WWCV20-964-150-FS	67.35
3"	3"	11/64"	150	NPT	11"	23-1/4"	WWCV30-1164-150-FS	112.6
4"	4"	11/64"	150	NPT	11"	23-1/4"	WWCV40-1164-150-FS	113

WASTE WASTER COMBINATION VALVE		
ITEM	DESCRIPTION	MATERIAL
1	BODY	DUCTILE IRON A536 (65-45-12)
2	COVER	DUCTILE IRON A536 (65-45-12)
3	LEVER FRAME	DUCTILE IRON A536 (65-45-12)
4	SEAT	EPDM
5	FLOAT	316SS
6	GASKET	NON-ASBESTOS FIBER
7	COVER BOLT	316SS
8	LEVER ARM	316SS
9	BUTTON	316SS/EPDM
10	PIVOT PIN/RETAINING RING	316SS/17-7 PH SS
11	FLOAT RETAINER	316SS
12	LEVER FRAME BRACKET	316SS
13	LOCK WASHER	316SS
14	LOCK NUT	316SS
15	1/2" PIPE PLUG	316SS
16	POPPET	316SS
17	GUIDE BUSHING	316SS
18	1" PIPE PLUG	316SS
19	2" PIPE PLUG	316SS
20	CLEVIS	316SS
21	EXTENSION SHAFT	316SS
22	SOCKET SET SCREW	316SS

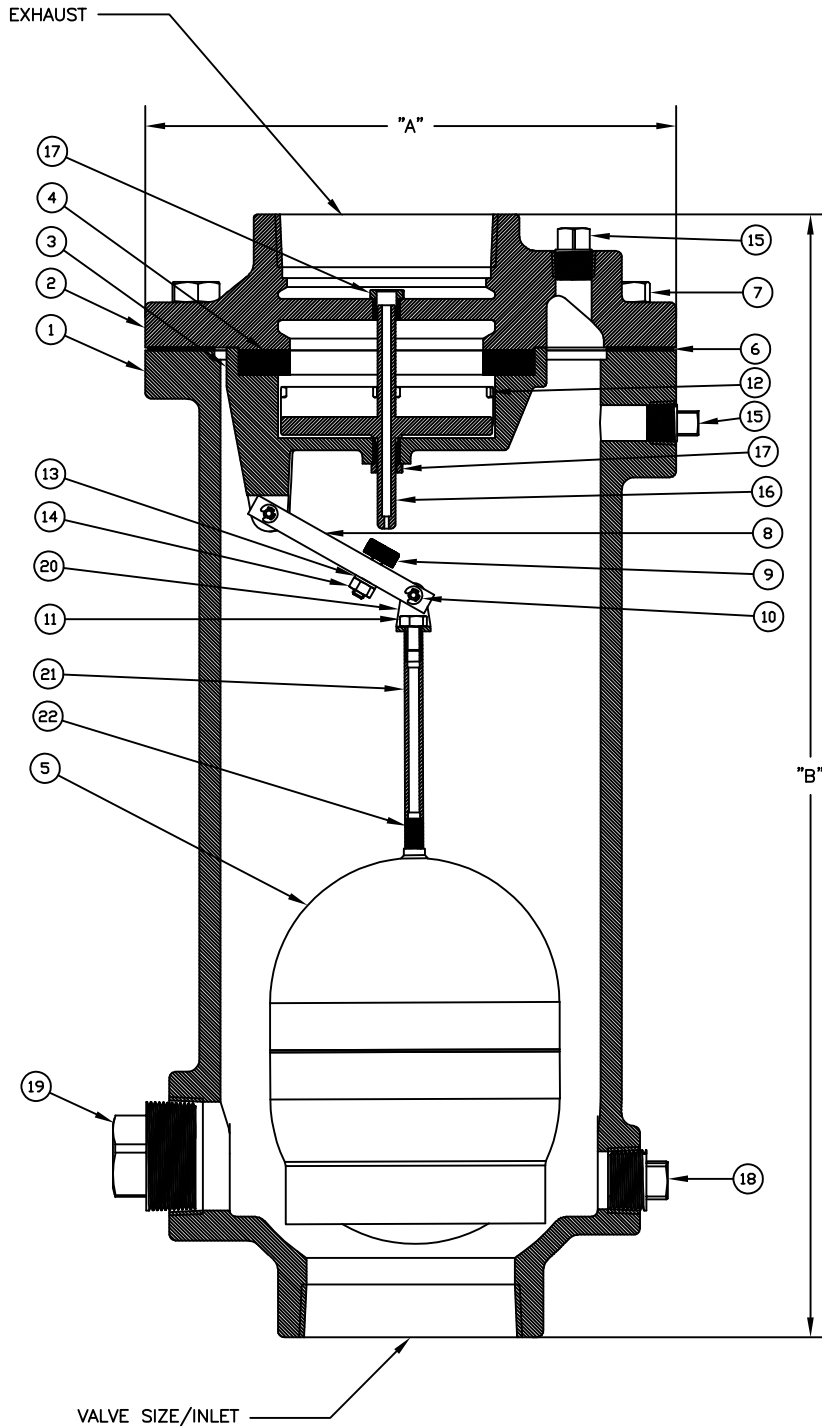

REV	DATE	DESCRIPTION	DWN	APP
1	2/22/18	REVISED P/N'S / MATERIAL / ADDED NOTES	JUR	SS
1	8/22/17	UPDATED GA	DSL	RF

**PRATT®**

2"-4" WWCV WASTE WATER COMBINATION AIR VALVES 150 PSI

SCALE	NONE	DATE	3/13/14
DRAWN BY	JUR	CHECKED BY	RCB
APPROVED	GA-BORDER		
DRWG. NO.	GA-11918	REV	2