

INLET SIZE (NPT)	COMBO NUMBER	AIR VACUUM MODEL	AIR RELEASE MODEL	PIPE KIT	A	B
1"	WCVD10-300-I-FS	WAV10-300-FS	WAR10-116-300-FS	2357289-AIR	8"	17"
2"	WCVD20-300-I-FS	WAV20-300-FS	WAR10-116-300-FS	2357289-AIR	10-1/2"	19"
3"	WCVD30-300-I-FS	WAV30-300-FS	WAR10-116-300-FS	2357289-AIR	10-1/2"	19"

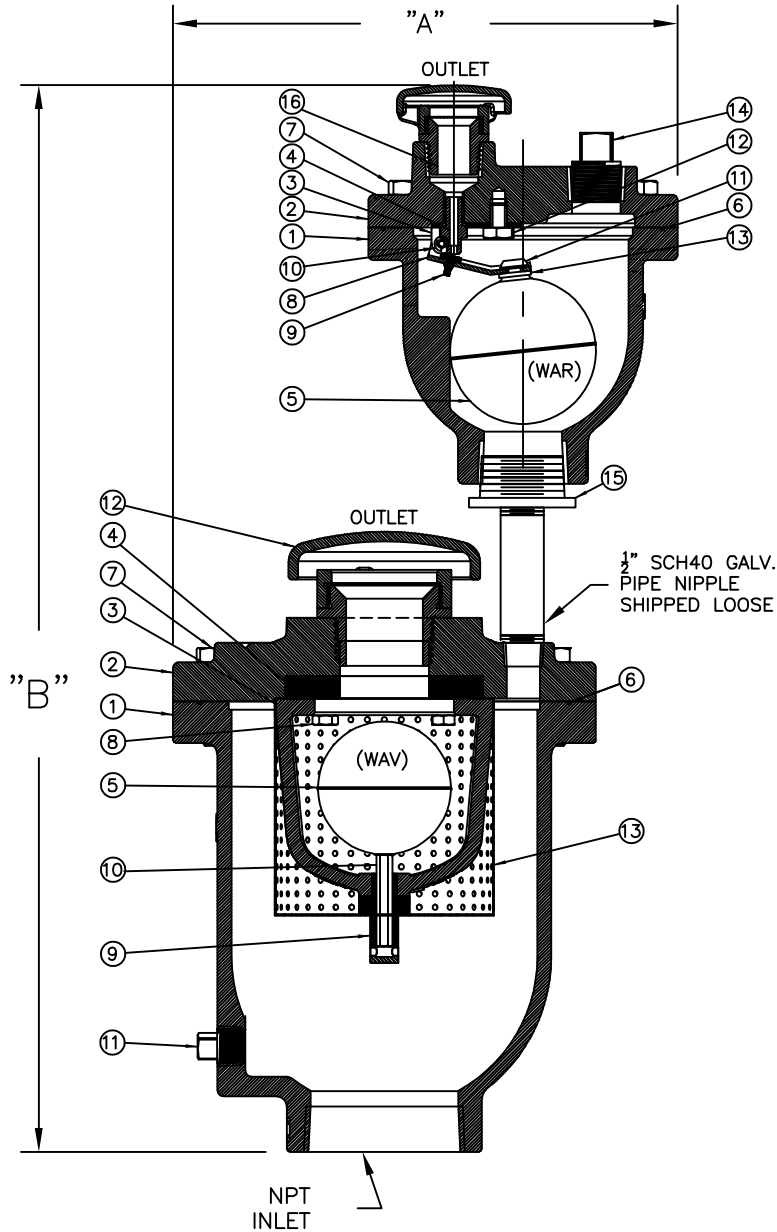

WAR PARTS		
ITEM	DESCRIPTION	MATERIAL
1	BODY	DUCTILE IRON A536 (65-45-12)
2	COVER	DUCTILE IRON A536 (65-45-12)
3	LEVER BRACKET	316SS
4	SEAT	316SS
5	FLOAT	316SS
6	O-RING	EPDM
7	COVER BOLT	316SS
8	LEVER ARM	316SS
9	BUTTON	EPDM
10	PIVOT PIN/RET. RING	316SS/17-7 PH SS
11	FLOAT TETAINER	316SS
12	POSITIONER	316SS
13	LOCK WASHER	316SS
14	1/2" PIPE PLUG	316SS
15	REDUCER BUSHING	316SS
16	VENT CAP	DUCTILE IRON A536 (65-45-12)/316SS SCREEN

WAV PARTS		
ITEM	DESCRIPTION	MATERIAL
1	BODY	DUCTILE IRON A536 (65-45-12)
2	COVER	DUCTILE IRON A536 (65-45-12)
3	BAFFLE	DUCTILE IRON A536 (65-45-12)
4	SEAT	EPDM
5	FLOAT	316SS
6	O-RING	EPDM
7	COVER BOLT	316SS
8	BAFFLE BRACKET BOLTS	316SS
9	GUIDE BUSHING	316SS
10	GUIDE SHAFT	316SS
11	1/2" PIPE PLUG	316SS
12	VENT CAP AND SCREEN	DUCTILE IRON A536/316SS SCREEN
13	DIFFUSER	PERFORATED 316SS

△	2/22/18	UPDATED GA	JUR	SS
△	8/22/17	UPDATED GA	JUR	RF
REV.	DATE	DESCRIPTION	BY	APP

PRATT

1"-3" WCVD  
DUAL BODY COMBINATION  
AIR VALVE

SCALE NONE DATE 8/16/2013

DRAWN BY JTC CHECKED BY

APPROVED GA-BORDER

DRWG. NO. GA-11921 REV 2 ^/C