

| ACTUATOR SIZE | J       | L       | M     | N      | P      | Q     | R       | S       | T       | V  | W       | NUMBER OF TURNS |
|---------------|---------|---------|-------|--------|--------|-------|---------|---------|---------|----|---------|-----------------|
| MDT-2S        | 4-11/16 | 2       | 2-1/8 | 2      | 4-1/2  | 4-1/2 | 8-1/4   | 7-7/8   | 7-7/8   | 8  | 9-1/8   | 32              |
| MDT-3S        | 5-5/8   | 2-7/16  | 3-1/4 | 3-5/32 | 5-5/8  | 5-3/8 | 10-3/8  | 10-1/2  | 10-1/8  | 12 | 9-1/8   | 30              |
| MDT-4S        | 6-3/8   | 2-27/32 | 3-3/8 | 4      | 7-5/16 | 6-3/4 | 11-5/16 | 11-1/2  | 11      | 12 | 9-1/8   | 40              |
| MDT-5         | 7-9/16  | 3-15/32 | 4-1/2 | 5-1/2  | 8-3/4  | 10    | 17      | 17 3/16 | 17-3/16 | 18 | 16-7/16 | 44              |

NOTES:

1. ALL DIMENSIONS SHOWN IN INCHES.
2. "D" DIMENSION  $\pm 1/16"$  FOR 3" THRU 10" VALVES.  
"D" DIMENSION  $\pm 1/8"$  FOR 12" THRU 20" VALVES.
3. DIMENSION "C" ALLOWS CLEARANCE FOR 125 LB OR 150 LB A.S.A. BOLT LAYOUT.
4. VALVES MANUFACTURED & TESTED IN ACCORDANCE WITH AWWA SPECIFICATION C-504 LATEST REVISION, CLASS 150B.

| VALVE SIZE | A      | B      | C      | D       |
|------------|--------|--------|--------|---------|
| 3          | 4-3/4  | 3-1/4  | 5-1/4  | 2-1/16  |
| 4          | 5-1/2  | 3-1/2  | 6-3/4  | 2-5/16  |
| 6          | 6-1/2  | 5-1/8  | 8-5/8  | 2-15/16 |
| 8          | 7-3/4  | 6-1/2  | 10-7/8 | 3-1/16  |
| 10         | 9      | 9-7/8  | 13-1/4 | 3-3/16  |
| 12         | 10-1/2 | 11-3/8 | 16     | 3-7/16  |
| 14         | 11-7/8 | 12-3/4 | 17-5/8 | 3-11/16 |
| 16         | 13-1/2 | 14-3/8 | 20-1/8 | 4-3/16  |
| 18         | 14-3/8 | 15-1/4 | 21-1/2 | 4-11/16 |
| 20         | 16     | 17     | 23-3/4 | 5-3/16  |

| VALVE SIZE | DISC O. D. | MIN. MATING I. D. |
|------------|------------|-------------------|
| 3          | 3.087      | 2.41              |
| 4          | 4.072      | 3.44              |
| 6          | 6.068      | 5.38              |
| 8          | 8.076      | 7.53              |
| 10         | 10.096     | 9.62              |
| 12         | 12.106     | 11.64             |
| 14         | 13.337     | 12.86             |
| 16         | 15.334     | 14.79             |
| 18         | 17.368     | 16.75             |
| 20         | 19.385     | 18.71             |

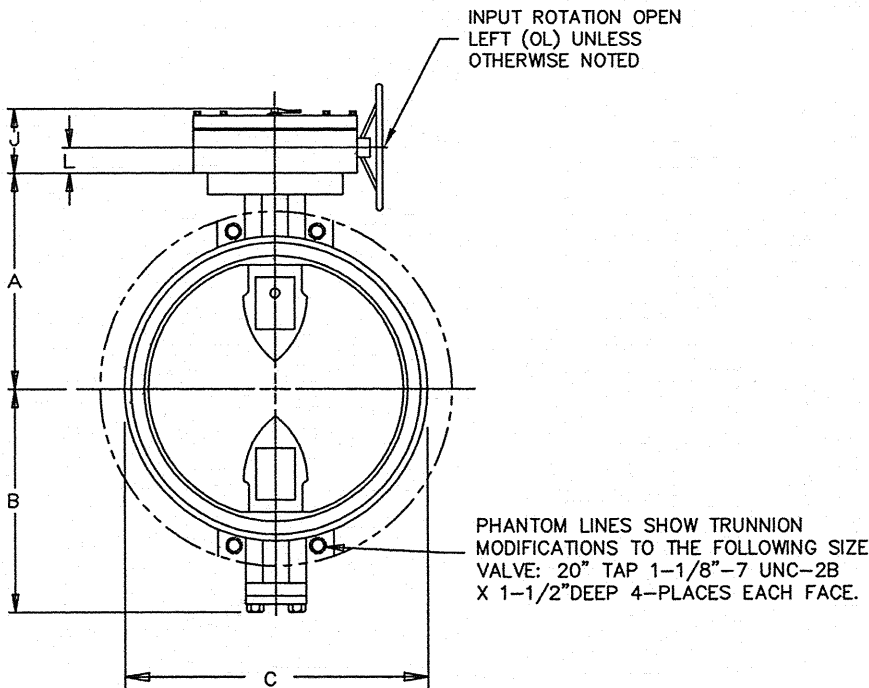
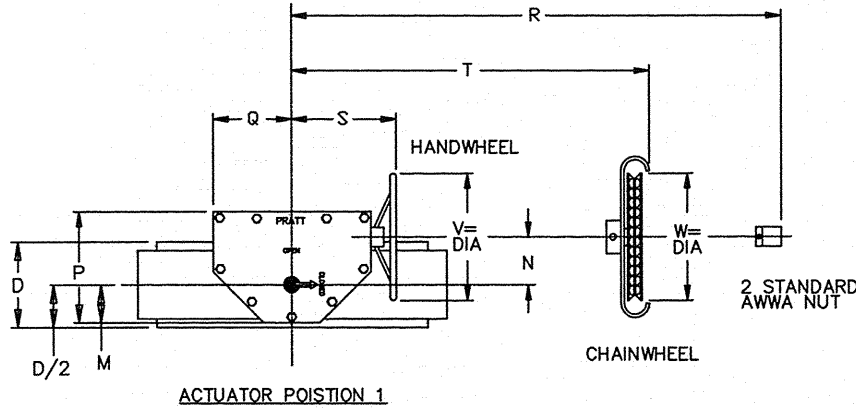

| REV | DATE     | DESCRIPTION              | DWN | APP |
|-----|----------|--------------------------|-----|-----|
| 1   | 07/18/17 | UPDATED TITLE BLOCK/LOGO | JWD | RE  |

**PRATT**

GENERAL ARRANGEMENT DRAWING  
MODEL MKII BUTTERFLY VALVE  
W/ MDT OPERATOR

SCALE NONE DATE 10/01/14

DRAWN BY AMJ CHECKED BY SS

APPROVED GA=BORDER

DRWG. NO. GA-11936 REV 1 A/C