

INSTALLATION DIAGRAM  
BOLTS, NUTS, GLANDS AND GASKETS FURNISHED BY OTHERS

OPTIONAL EXTENSION STEM ARRANGEMENT

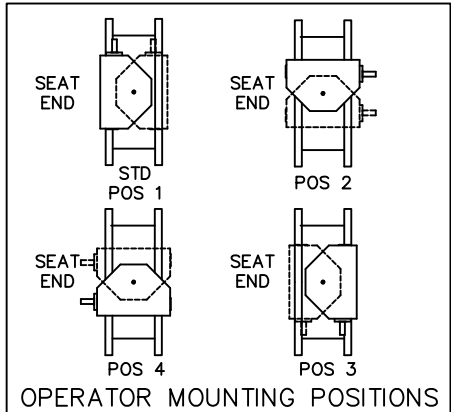

A. CHECK WITH FACTORY WHEN SELECTING ALTERNATE MIRROR ACTUATOR STYLES.

NOTES:

1. ALL DIMENSIONS SHOWN IN INCHES.
2. "D" DIMENSION ±1/8".
3. FOR BOLTS SMALLER THAN Ø1-3/4, BOLT HOLES WILL BE 1/8" LARGER THAN DIAMETER OF BOLT. FOR BOLTS Ø1-3/4 OR LARGER, BOLT HOLES WILL BE 1/4" LARGER THAN DIAMETER OF BOLT.
4. DIMENSIONS & DRILLING OF MECHANICAL JOINT ENDS CONFORM TO ANSI/ AWWA C111/ A21.11
5. CAUTION: IT IS RECOMMENDED THAT VALVES BE INSTALLED INTO THE PIPING SYSTEM IN ACCORDANCE WITH AWWA M-11 IN ORDER TO PREVENT ANY UNDUE PIPING STRESS, DEFLECTION OR BENDING THAT MAY EFFECT THE PERFORMANCE OF THE VALVE.
6. EXTENSION STEM CAN BE USED WITH STANDARD VALVE BOXES OR 5" SOIL PIPE.

| VALVE SIZE | A      | B      | C       | D      | E       | F         | G      | X     |
|------------|--------|--------|---------|--------|---------|-----------|--------|-------|
| 6          | 7-1/4  | 8-3/8  | 11-1/16 | 10     | 1-1/16  | 6--3/4    | 9-1/2  | 5     |
| 8          | 8-1/2  | 9-5/8  | 13-5/16 | 10     | 1-1/8   | 6--3/4    | 11-3/4 | 5     |
| 10         | 9-3/4  | 11     | 15-5/8  | 10     | 1-3/16  | 8--3/4    | 14     | 5     |
| 12         | 11-1/2 | 12-5/8 | 17-7/8  | 10     | 1-1/4   | 8--3/4    | 16-1/4 | 5     |
| 14         | 12-3/4 | 13-7/8 | 20-1/4  | 12-1/2 | 1-5/16  | 10--3/4   | 18-3/4 | 5-1/2 |
| 16         | 14     | 15-1/8 | 22-1/2  | 12-1/2 | 1-3/8   | 12--3/4   | 21     | 5-1/2 |
| 18         | 15-1/4 | 16-3/8 | 24-3/4  | 13-1/4 | 1-7/16  | 12--3/4   | 23-1/4 | 6-1/4 |
| 20         | 17     | 17-5/8 | 27      | 13-1/4 | 1-1/2   | 14--3/4   | 25-1/2 | 6-1/4 |
| 24         | 19-3/4 | 20-1/4 | 31-1/2  | 13-1/4 | 1-5/8   | 16--3/4   | 30     | 6-1/4 |
| 30         | 25-5/8 | 25-1/2 | 39      | 18     | 1-13/16 | 20--1-1/8 | 36-7/8 | 10    |
| 36         | 28-1/8 | 30-5/8 | 45-7/8  | 22     | 2       | 24--1-1/8 | 43-3/4 | 14    |

| ACTUATOR SIZE | J       | L       | M     | N      | P      | Q        | R       | NUMBER OF TURNS |
|---------------|---------|---------|-------|--------|--------|----------|---------|-----------------|
| MDT-2S        | 4-11/16 | 2       | 2-1/8 | 2      | 4-1/2  | 4-1/4    | 8-1/4   | 32              |
| MDT-3S        | 5-5/8   | 2-7/16  | 3-1/4 | 3-5/32 | 5-5/8  | 5-3/8    | 10-3/8  | 30              |
| MDT-4S        | 6-3/8   | 2-27/32 | 3-3/8 | 4      | 7-5/16 | 6-3/4    | 11-5/16 | 40              |
| MDT-5         | 7-9/16  | 3-15/32 | 4-1/2 | 5-1/2  | 8-3/4  | 10-7/16  | 17      | 44              |
| MDT-5S        | 8-5/16  | 3-15/16 | 5-1/2 | 3-5/8  | 10-1/2 | 15-15/16 | 18-5/8  | 136             |
| MDT-6S        | 10-3/16 | 5-1/16  | 7     | 8-1/4  | 12-5/8 | 18-9/16  | 26-1/2  | 215             |

| REV | DATE     | DESCRIPTION  | DWN | APP |
|-----|----------|--|-----|-----|
| 6   | 5/1/23   | ADDED POSITION CHART                                 | RTF | RF  |
| 5   | 09/17/21 | REMOVE NOTE FOR RECOMMENDED FLOW DIRECTION FOR HP350 | CA  | TF  |
| 4   | 10/13/16 | CORRECTED TITLE MDT WAS MTD                          | MZ  | SS  |
| 3   | 09/12/16 | REVISED FLOW DIRECTION NOTE                          | SAD | SS  |
| 2   | 05/15/15 | ADDED VALVES SIZES 30 & 36 ADDED MDT 5 & 6S          | AMJ | RF  |
| 1   | 01/28/10 | 2-27/32 WAS 3-7/16; 3-15/32 WAS 3-1/2                | MZ  | CEM |

**PRATT**  
a MUELLER brand

TRITON HP-350 MECHANICAL JOINT ENDS  
MDT  
BURIED SERVICE ACTUATOR

SCALE NONE DATE 11/19/09

DRAWN BY AA CHECKED BY JR

APPROVED GA=BORDER

DRWG. NO. GA-12070 REV 6 AYC