

VALVE SIZE	OUTLET SIZE	MAX C.W.P	INLET CONNECTION	W	H	PRATT PN	WT. LBS
2"	1"	150	NPT	7"	14-7/8"	WWAV20-1-150-FS	40.6
2"	2"	150	NPT	9-1/2"	17-5/16"	WWAV20-150-FS	65.8
3"	3"	150	NPT	9-1/2"	17-5/8"	WWAV30-150-FS	69.5

ITEM	DESCRIPTION	MATERIAL
1	BODY	DUCTILE IRON A536 (65-45-12)
2	COVER	DUCTILE IRON A536 (65-45-12)
3	BAFFLE	DUCTILE IRON A536 (65-45-12)
4	SEAT	EPDM
5	FLOAT	316SS
6	O-RING	EPDM
7	COVER BOLT	316SS
8	BAFFLE BRACKET	316SS
9	GUIDE BUSHING	316SS
10	GUIDE SHAFT	316SS
11	1/2" PIPE PLUG	316SS
12	1" PIPE PLUG	316SS
13	2" PIPE PLUG	316SS
14	FLOAT	316SS

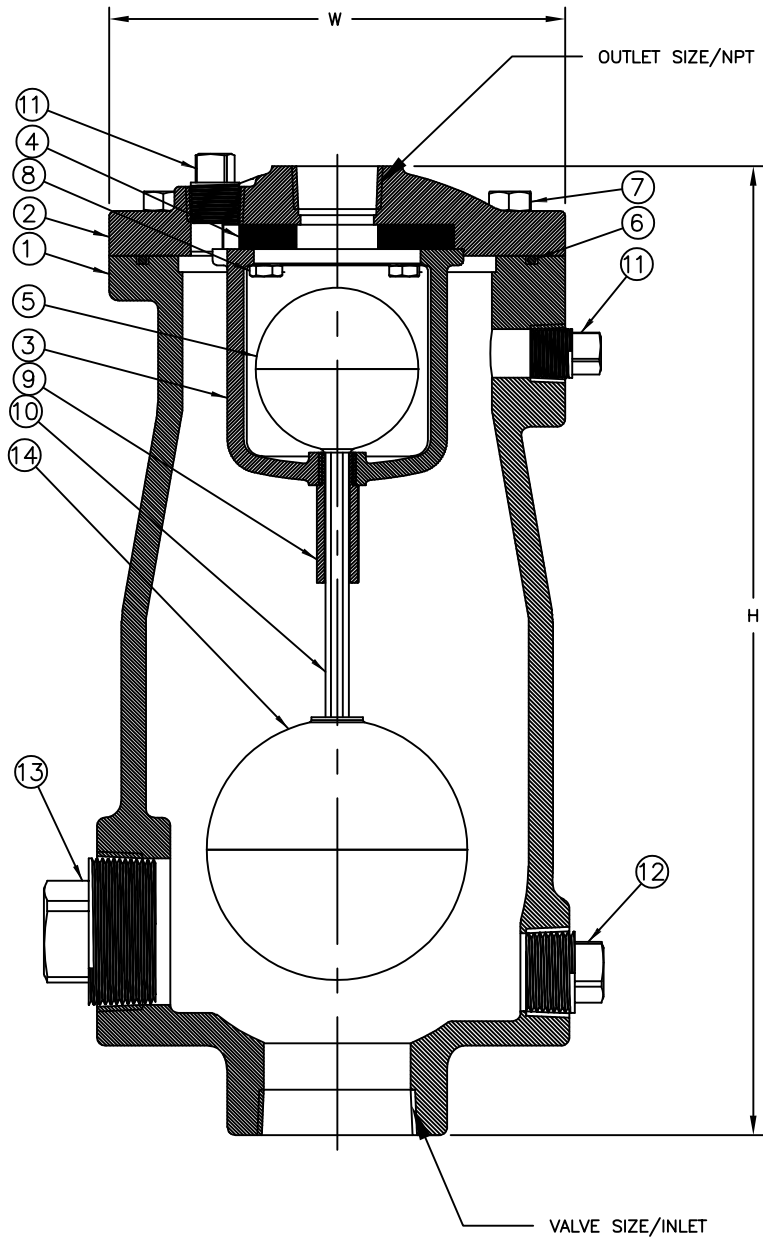

REV	DATE	REVISED PN'S/ MATERIAL/ TITLE, ADDED NOTES	JUR	SS
1	2/22/18		DWN	APP

PRATT

2" & 3" WWAV WASTEWATER AIR VACUUM VALVE

SCALE NONE DATE 8/12/17

DRAWN BY DSL CHECKED BY RF

APPROVED GA=BORDER

DRWG. NO. GA-12417 REV 1