

A.V. PIPE SIZE	AIR VACUUM MODEL	INLET CONNECTION	A	B	WT. (LBS)
4"	WWAV40-150F-FS	#125 FLG	12"	36-1/2"	178
6"	WWAV60-150F-FS	#125 FLG	14"	36-1/2"	250
8"	WWAV80-150F-FS	#125 FLG	18"	41-1/4"	417

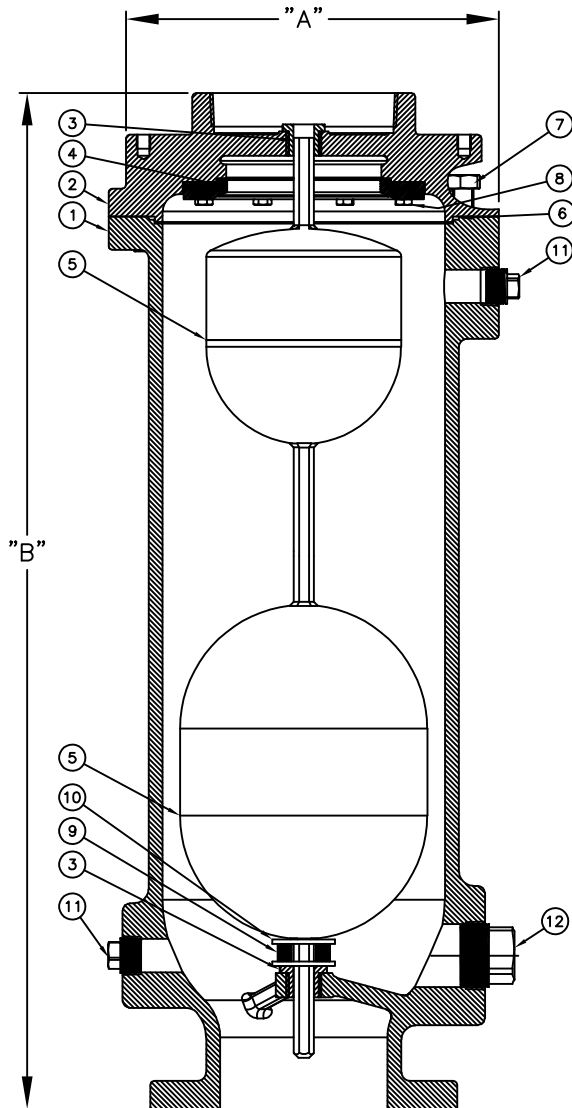

AIR VACUUM VALVE (WWAV)		
ITEM	DESCRIPTION	MATERIAL
1	BODY	DUCTILE IRON A536 (65-45-12)
2	COVER	DUCTILE IRON A536 (65-45-12)
3	BUSHING	316SS
4	SEAT	EPDM
5	FLOAT	316SS
6	O-RING	EPDM
7	COVER BOLT	316SS
8	SHOULDER SCREW	316SS
9	CUSHION BUMPER	EPDM
10	WASHER	316SS
11	1" PIPE PLUG	316SS
12	2" PIPE PLUG	316SS

REV	DATE	REVISIONS/ MATERIAL/ ADDED NOTES	JUR	SS	
1	2/22/18		JUR	SS	
		DESCRIPTION	DWN	APP	
PRATT					
4"-8" WWAV WASTEWATER AIR VACUUM VALVES					
SCALE <u>NONE</u> DATE <u>9/13/17</u>					
DRAWN BY <u>RTF</u> CHECKED BY <u>JUR</u>					
APPROVED _____ GA= BORDER					
DRWG. NO. <u>GA-12418</u>				REV <u>1</u>	<u>AYC</u>