

| SIZE | L | L1 | ØD | ØD1 | F | ØB | PCD | N-Ø | WEIGHT(LBS) |
|------|-------|------|-------|-------|------|-------|-------|---------|-------------|
| 2" | 5.24 | 0.47 | 2.20 | 2.36 | 0.63 | 6.00 | 4.75 | 4-0.75 | 16.50 |
| 2.5" | 5.50 | 0.04 | 2.87 | 2.95 | 0.69 | 7.00 | 5.50 | 4-0.75 | 20.00 |
| 3" | 6.00 | 0.39 | 3.35 | 3.54 | 0.75 | 7.52 | 6.00 | 4-0.75 | 26.50 |
| 4" | 7.25 | 0.51 | 4.17 | 4.33 | 0.75 | 9.00 | 7.50 | 8-0.75 | 35.50 |
| 6" | 9.75 | 0.31 | 6.06 | 6.30 | 0.75 | 11.00 | 9.50 | 8-0.875 | 64.00 |
| 8" | 12.50 | 0.35 | 8.19 | 8.11 | 0.79 | 13.50 | 11.75 | 8-0.875 | 128.00 |
| 10" | 15.50 | 2.36 | 10.16 | 10.23 | 0.87 | 16.00 | 14.25 | 12-1 | 174.50 |
| 12" | 14.25 | 0.43 | 12.13 | 12.2 | 0.98 | 19.00 | 17.00 | 12-1 | 249.50 |

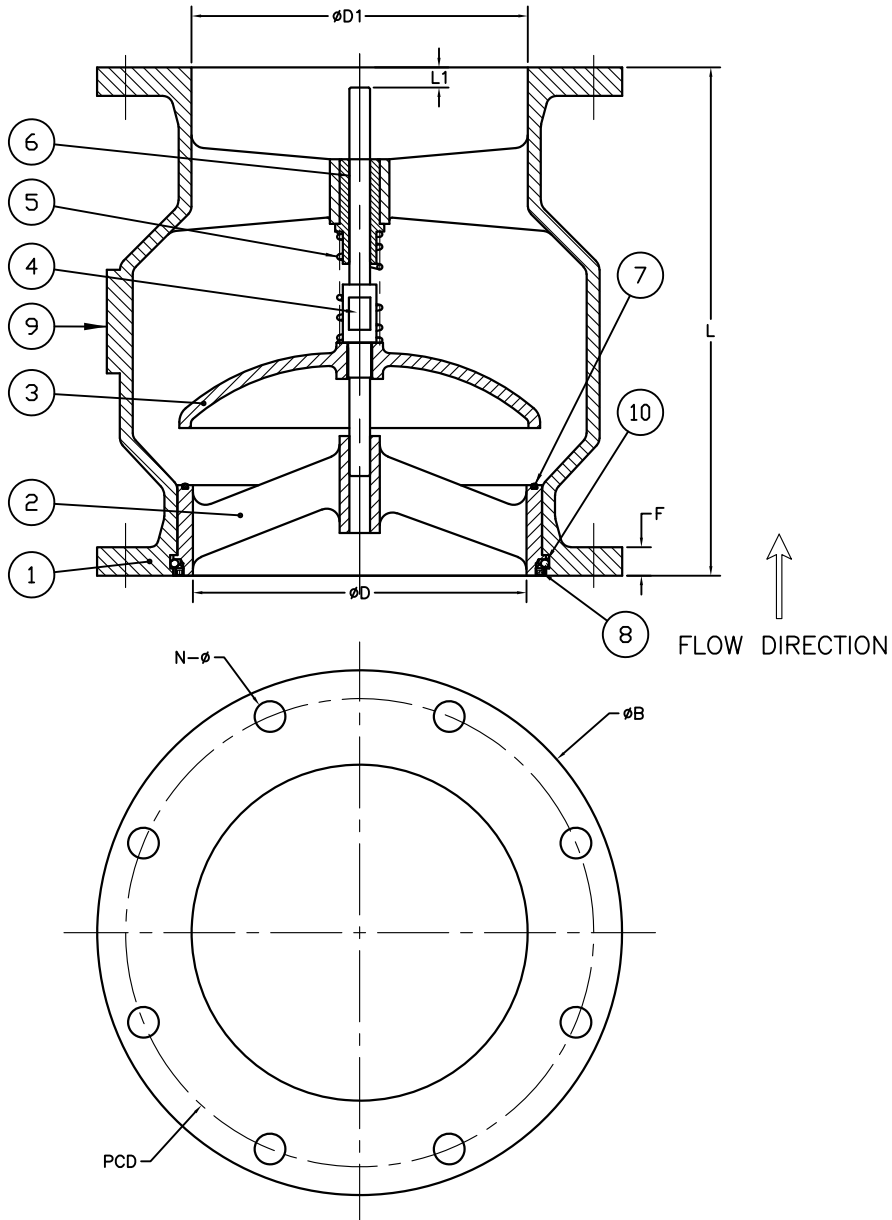

| REV | ECN | DESCRIPTION | DATE | DWN | APP |
|-----|-----|-------------------------------------|---------|-----|-----|
| 1 | N/A | UPDATED PER SUPPLIER LATEST DRAWING | 6/18/18 | JUR | JR |
| 2 | N/A | UPDATED TITLE | 7/13/18 | JUR | |
| 3 | N/A | ADDED L1 DIMENSION | 4/22/20 | TT | JL |

NOTES:

1. FLAT FLANGES AND RING GASKETS (RUBBER OR COMPRESSED FIBER) ARE REQUIRED.
2. THE MATING COMPANION FLANGE I.D. MUST OVERLAP THE VALVE SEAT. THIS IS REQUIRED TO PROVIDE PROPER SEAT RETENTION.
3. THE FLANGE GASKET MUST BE PROPERLY CENTERED AND OF THE SIZE INDICATED. THIS IS REQUIRED TO ACHIEVE A SEAL BETWEEN THE SEAT O.D. AND THE BODY I.D. INTERFACE AREA.

*GASKET SUPPLIED BY OTHERS

| VALVE SIZE | MAX. ALLOWABLE ID OF FLG | *STD RING GASKET DIMENSIONS | |
|------------|--------------------------|-----------------------------|-------------------------|
| | | GASKET I.D. | OD FOR 125LB GLOBE TYPE |
| 2" | 2.76 | 2.56 | 4.09 |
| 2.5" | 2.76 | 2.87 | 4.84 |
| 3" | 3.35 | 3.50 | 5.35 |
| 4" | 4.72 | 4.53 | 6.46 |
| 6" | 6.5 | 6.42 | 8.66 |
| 8" | 8.27 | 8.46 | 10.67 |
| 10" | 10.24 | 10.16 | 13.03 |
| 12" | 12.40 | 12.20 | 14.84 |

| ITEM | DESCRIPTION | QTY | MATERIAL |
|------|---------------|-----|--|
| 1 | BODY | 1 | DUCTILE IRON ASTM A-536 (65-45-12) |
| 2 | SEAT | 1 | 304 STAINLESS STEEL |
| 3 | DISC | 1 | 304 STAINLESS STEEL |
| 4 | STEM | 1 | 304 STAINLESS STEEL |
| 5 | SPRING | 1 | 316 STAINLESS STEEL |
| 6 | GUIDE BUSHING | 1 | BRONZE ASTM B584 |
| 7 | SEAL | 1 | EPDM |
| 8 | SET SCREW | 2 | 304 STAINLESS STEEL |
| 9 | NAME PLATE | 1 | 304 STAINLESS STEEL |
| 10 | STEEL BALL | 2 | 316 STAINLESS STEEL |

| | | | |
|---|---|-------------------|---------------|
| DRAWN BY: JUR | PRATT <small>• MUELLER brand</small> | | C A D |
| DRAWN DATE: 12/20/17 | | | |
| APPROVED BY: AA | TITLE: 2"-12" SERIES 821G GLOBE STYLE CHECK VALVE 250 PSI /W 125# FLG DRILLING | | |
| APPROVED DATE: | | | |
| PROPRIETARY INFORMATION DO NOT COPY OR REPRODUCE WITHOUT WRITTEN PERMISSION | SIZE: A | PART # ----- | SHEET: 1 OF 1 |
| FILE LOCATION: H:\S\GA | SCALE: NTS | DRAWING: GA-12436 | REV: 3 |