

DETAIL VIEW A

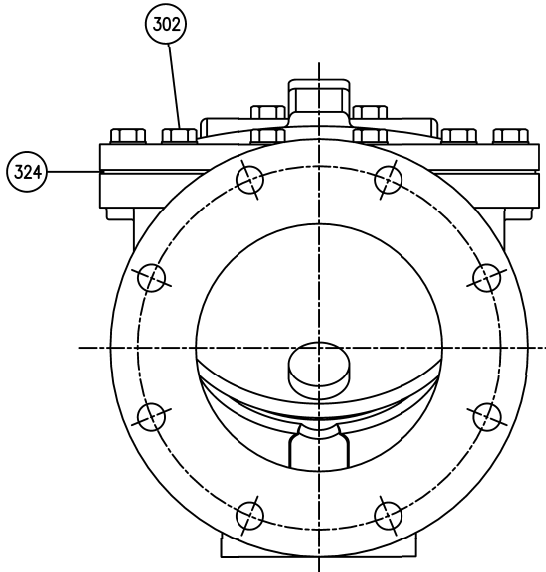
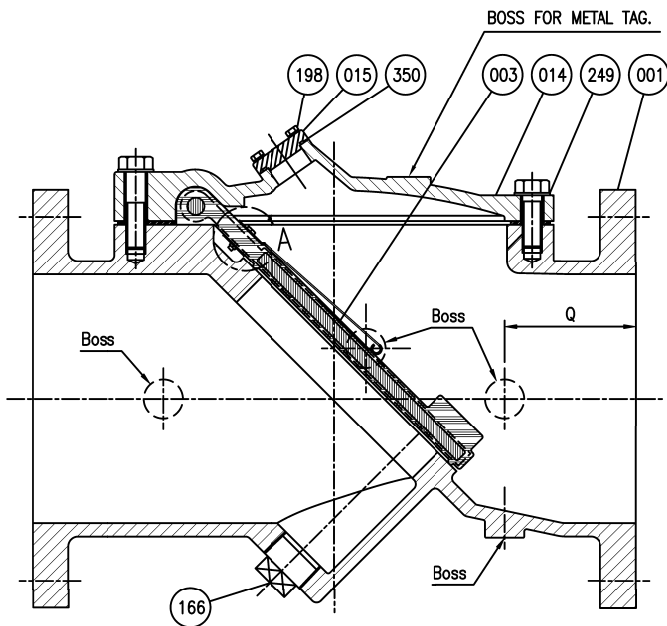

819	Surge Hex Nut	Stainless Steel	Type 316	AR
818	Surge Bolts	Stainless Steel	Type 316	AR
817	Surge Back Plate	Stainless Steel	Type 301	1
816	Surge Inhibitor	Stainless Steel	Type 301	1
302	Cover Bolt	<input type="checkbox"/> Galvanized Steel	A307 Grade B (Standard)	1set
		<input type="checkbox"/> 316SS	ASTM A193 Grade B8M (Optional)	
		<input type="checkbox"/> Hastelloy	C276 (Optional for AIS)	
350	O-Ring A	<input type="checkbox"/> Rubber (EPDM)	ASTM D2000 CA707 (Optional)	1
		<input type="checkbox"/> Rubber (BUNA-N)	D 2000 BK 707 (Standard)	1
324	Cover Gasket	<input type="checkbox"/> Rubber (EPDM)	ASTM D2000 CA807 (Optional)	1
		<input type="checkbox"/> Rubber (BUNA-N)	D 2000 BK 707 (Standard)	1
249	Washer	<input type="checkbox"/> Galvanized Steel	A307 Grade B (Standard)	1set
		<input type="checkbox"/> 316SS	ASTM A193 Grade B8M (Optional)	
		<input type="checkbox"/> Hastelloy	C276 (Optional for AIS)	
198	End Plate Bolt	Galvanized Steel	A 307 Grade B	1set
166	Plug	Stainless Steel	A 276 Type 304	1
015	End Plate	Ductile Iron	A 536 Gr.65-45-12	1
014	Cover	Ductile Iron	A 536 Gr.65-45-12	1
003	Disc	Steel	A 36	1
		<input type="checkbox"/> Rubber (EPDM)	ASTM D2000 CA707 (Optional)	
		<input type="checkbox"/> Rubber (BUNA-N)	D 2000 BK 707 (Standard)	
001	Body	Ductile Iron	A 536 Gr.65-45-12	1
NO.	PARTS	MATERIAL	ASTM.DESIGNATION.	Q' TY

MATERIAL LIST

HYDRO SHELL 500 PSI.

HYDRO VALVE SEAT 250 PSI.

TEST PRESSURE

WORKING PRESSURE 250 PSI.

ISSUE NUM.	PRATT <small>a MUELLER brand</small>		BY: CA	DATE: 07/24/20	SCALE: NONE	
			CHK'D BY:	DIMENSION: INCHES		
	DATE	REVISIONS	BY	CHK	TITLE 2"-24" FIG. 851 FLEX CHECK VALVE W/SURGE INHIBITOR DEVICE 250PSI, ANSI 125 FLANGES	
	1					
2						
3						
4					DWG. NO. HP50682	

SEE DRAWING HP50675 & HP50676 FOR DETAIL DIMENSIONS