

PRATT®

a **MUELLER** brand

LVC FIGURE 65 URETHANE LINED DUCTILE IRON BODY Knife Gate Valve

FEATURES

- Heavy duty cast ductile iron body, packing gland and yoke for the most rugged service.
- Heavy duty solid lug body design.
- Urethane liner and seat provide bi-directional bubble tight seal across gate from 0 to 150 PSI.
- Seat is flush with the bottom of the port, eliminating pockets in the bottom of the valve to collect material in media such as slurries, pellets, or powders.
- Urethane liner is a one-piece, molded-in-place full body liner with integral seat for temperatures to 165°F.
- Stainless steel gate and stem provide corrosion resistance and durability.
- MSS SP-81 face-to-face and flange dimensions.
- Easy conversion from handwheel operator to hydraulic or pneumatic cylinder, bevel gear, chainwheel, electric motor, or fail safe spring cylinder operator using existing cast yoke.
- Enclosed bronze stem bushing provides reduced operating torque and protects the stem bushing in harsh environments.
- Superior packing arrangement provides improved sealing performance in high cycle applications.
- Full packing seal around gate minimizes the potential for packing leakage.
- Minimum 4 bolt packing gland to assure proper gland alignment in all sizes.
- Standard TFE lubricated synthetic packing (TLSP).
- Time proven urethane liner provides the best resistance in abrasive applications.
- Full port ID.
- MSS SP-81 Stainless Steel, Bonnetless, Flanged Knife Gate Valves.
- CRN Registered.



MUELLER

MATERIALS OF CONSTRUCTION

MODEL 65

1	Gate	SS
2	Body	DI
3	Seat	Urethane
4	Bolts	Plated
5	Packing	TLSP*
6	Gland	DI
7	Stem	SS
8	Yoke	DI
9	Stem Nut	Bronze
10	Handwheel	DI

**TLSP = TFE Lubricated Synthetic Packing.

Normally supplied with handwheel for manual operation, but can be modified for chain wheel, bevel gear, fail safe spring cylinder, electric motor, hydraulic or pneumatic cylinder operator.

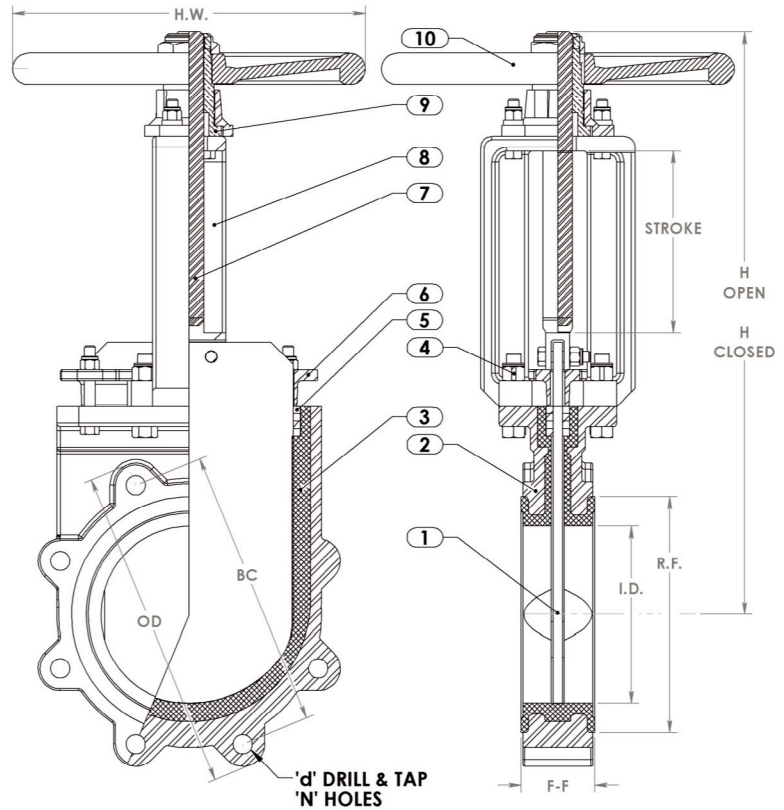

DIMENSIONS (INCHES) AND WEIGHTS

	SIZE	2	3	4	6	8	10	12	14	16	18	20	24
Face-to-Face	F-F	1-7/8	2	2	2-1/2	2-3/4	2-3/4	3	3	3-1/2	3-1/2	4-1/2	4-1/2
Flange OD	OD	6	7-1/2	9	11	13-1/2	16	19	21	23-1/2	25	27-1/2	32
Bolt Circle	BC	4-3/4	6	7-1/2	9-1/2	11-3/4	14-1/4	17	18-3/4	21-1/4	22-3/4	25	29-1/2
Flanged Raised Face	RF	3-1/4	4-1/4	6-3/16	8-1/2	10-5/8	12-3/4	15	16-1/4	18-11/16	20-1/4	22-1/2	27
Inside Diameter	ID	2	3	3-3/4	6	7-3/4	9-3/4	11-3/4	13-1/4	15	17-1/4	19-1/4	23-1/4
No. of Bolt Holes	N	4	4	8	8	8	12	12	12	16	16	20	20
Hole D&T Size	D	5/8"-11	5/8"-11	5/8"-11	3/4"-10	3/4"-10	7/8"-9	7/8"-9	1"-8	1"-8	1-1/8"-7	1-1/8"-7	1-1/4"-7
C/L to Top-Closed	H-CLS	13-7/8	14-5/8	17-1/4	20-1/8	24-3/8	29	32-7/8"	36-3/4	41	47	51-3/4	58-3/4
C/L to Top-Open	H-OPN	16	17-11/16	21-3/16	26-1/2	32-5/8	39	45	50-1/4	56-1/4	64-1/2	72-1/4	82-1/4
Handwheel Dia.	H/W	8	8	12	16	16	16	16	24	24	24	24	24
Weight - lbs	WT	20	29	46	75	118	180	295	345	420	545	805	1150
Stroke	S	2-1/8	3-1/16	3-15/16	6-3/8	8-1/4	10	12-1/8	13-1/2	15-1/4	17-1/2	20-1/2	23-1/2

675 Mitchell Avenue, Woodland, WA 98674, moreinfo@prattvalve.com, P: 800.423.1323

Mueller refers to one or more of Mueller Water Products, Inc., a Delaware corporation ("MWP"), and its subsidiaries. MWP and each of its subsidiaries are legally separate and independent entities when providing products and services. MWP does not provide products or services to third parties. MWP and each of its subsidiaries are liable only for their own acts and omissions and not those of each other. MWP brands include Mueller®, Echologics®, Hydro Gate®, Hydro-Guard®, Jones®, Mi.Net®, Milliken®, Pratt®, Singer®, and U.S. Pipe Valve & Hydrant. Please see www.muellerwp.com/about to learn more.

Copyright © 2018 Henry Pratt Company, LLC. All Rights Reserved. The trademarks, logos and service marks displayed in this document are the property of Mueller Water Products, Inc., its affiliates or other third parties. Products above marked with a section symbol (§) are subject to patents or patent applications. For details, visit www.mwppat.com. These products are intended for use in potable water applications. Please contact your Mueller Sales or Customer Service Representative concerning any other application(s).