

PRATT®

a MUELLER brand

RD-SERIES®

Check Valve



CONSTRUCTION SPECIFICATIONS

SIZES	2" Through 24" Flanged Ends 3" Through 16" Mechanical Joint Ends
BODY	Ductile Iron
DISC	Buna-N Encapsulated Steel
SEAT	45° Non-Slam Seat

Manufactured to comply with AWWA C508, the Pratt® RD-Series® Check Valve has only one moving part: a resilient disc reinforced with steel. This simple, innovative valve provides dependable, maintenance free performance, and quiet operation with its inherent non-slam construction. The large, unobstructed flow path makes the valve an excellent choice for wastewater as well as water applications. The design has undergone a rigorous 1,000,000 continuous cycle test with no signs of wear or distortion to the valve disc or seat. All sizes have a 250 psi rating and are NSF / ANSI 61 / 372 certified.

FEATURES

BODY

Ductile Iron in ASTM A-536 Grade 65-45-12, and features a full flow area providing 100% unrestricted flow and low head loss. Flanges are in full compliance with ANSI B16.1, Class 125.

BONNET

Ductile iron domed access bonnet allows for easy removal and inspection of the flexible disc assembly.

DISC

The only moving part, featuring a fully Buna-N encapsulated steel disc with nylon reinforcement in the flex area. The molded elastomer with integral O-ring ensures a bubble-tight shut off, without backflow.

BODY SEAT

Constructed on a 45 degree angle to reduce the travel of the disc to the full open position; significantly reducing the potential for water hammer.

FLOW

The flow area is equal to or greater than the equivalent pipe size throughout, resulting in low head losses, compared to other types of check valves.

INSTALLATION

Suitable for both horizontal and vertical pipelines with flow upward.

COATINGS

The valve interior is fully coated with liquid thermosetting epoxy suitable for use in potable water service. The exterior is provided as standard with a universal primer enamel suitable for coating in the field. Special coatings can be furnished on request.

ACCESSORIES/OPTIONS

- Disc position indicator
- External backflow device - to manually open disc
- Proximity limit switch - to transmit an electrical signal to indicate when disc is open or closed
- EPDM disc option
- Stainless steel cover bolts
- Spring assisted closure

MUELLER

MATERIALS OF CONSTRUCTION

ITEM	QTY	DESCRIPTION	MATERIAL	ASTM DESIGNATION
1	1	Body	Ductile Iron	ASTM A-536-GR 65-45-12
2	1	Bonnet	Ductile Iron	ASTM A-536-GR 65-45-12
3	1	Disc	Steel/Buna-N	ASTM-A36 D2000 BK 807
4	1	Gasket	Rubber (Buna N)	D2000 BK 807
5	AR	Cap Bolts	Steel/Zinc	SAE Grade 5 - Zinc Plated
6	1	Interior Lining	Epoxy	—
7	1	Plug	Ductile Iron	ASTM A-536-GR 65-45-12
8	1	Boss Cover	Ductile Iron	ASTM A-536-GR 65-45-12
9	1	O-Ring	Rubber (Buna)	D2000 BK 807
10	4	Boss Cover Bolts	Steel/Zinc	SAE Grade 5 - Zinc Plated

AR = As Required

SUGGESTED SPECIFICATION

Check valve shall be of the flanged, full body type with no internal moving parts except for the resilient disc. The flanged ends shall be manufactured in accordance with ANSI B16.1 Class 125. Valves shall be rated to 250 psi for all sizes.

The valves used in potable water service shall be certified to NSF / ANSI 61 Drinking Water System Components – Health Effects, and certified to be Lead-Free in accordance with NSF / ANSI 372.

The valve body shall be constructed of ductile iron ASTM A-536 Grade 65-45-12 with flow area equal to the nominal pipe inside diameter throughout the valve. Seat shall be constructed on a 45 degree angle to reduce disc travel. The seat and internal body shall be fully coated with a two part thermosetting epoxy suitable for use in both potable water and wastewater applications.

The domed bonnet shall be manufactured of ductile iron ASTM A-536 Grade 65-45-12. The bonnet-to-body seal shall be provided by a gasket to allow easy removal and replacement of the access bonnet. Bonnet bolting shall be SAE Grade 5.

The resilient disc shall feature a fully encapsulated steel pressure plate with integral molded O-ring on the face of the elastomer. Nylon reinforcements shall be provided in the flexible hinge area of the disc assembly.

If requested the manufacturer shall furnish certified results of a proof of design test performed at an independent testing laboratory. Testing shall include a million-cycle continuous test to demonstrate the durability of the flexible connection.

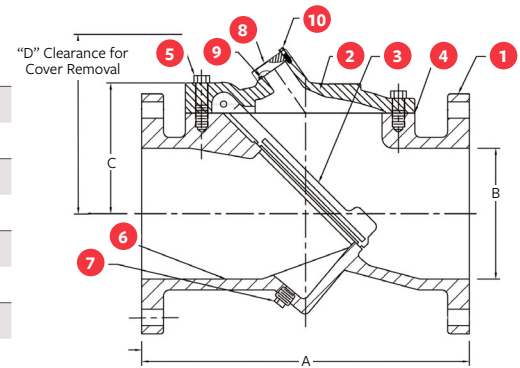

FLANGES ARE PER ANSI B16.1 CLASS 125/150 FLAT FACED

*Mechanical Joint Drawings and Dimensions are Available at www.prattvalve.com

DIMENSION 'D' CLEARANCE REQUIRED TO REMOVE ACCESS COVER

VALVE SIZE	A	B	C	D
2	8.0	2.0	3.38	8.38
2-1/2	8.5	2.5	3.38	8.38
3	9.5	3.0	3.88	9.00
4	11.5	4.0	4.63	9.63
5	13.75	5.0	5.13	10.25
6	15.0	6.0	5.88	11.00
8	19.5	8.0	7.63	13.75
10	24.5	10.0	9.88	16.00
12	27.5	12.0	11.38	18.50
14	31.0	14.0	13.38	20.50
16	32.0	16.0	15.38	23.50
18	36.0	18.0	17.13	25.25
20	40.0	20.0	19.13	29.25
24	48.0	24.0	22.75	32.75

401 S. Highland Ave., Aurora, IL 60506, moreinfo@prattvalve.com, **P: 1.800.423.1323**

For more information about Pratt or to view our full line of water products, please visit www.prattvalve.com or call Pratt customer service at 1.800.423.1323.

Mueller refers to one or more of Mueller Water Products, Inc., a Delaware corporation ("MWP"), and its subsidiaries. MWP and each of subsidiaries are legally separate and independent entities when providing products and services. MWP does not provide products or services to third parties. MWP and each of its subsidiaries are liable only for their own acts and omissions and not those of each other. MWP brands include Mueller®, Echologics®, Hydro Gate®, Hydro-Guard®, Jones®, Mi.Net®, Milliken®, Pratt®, Singer®, and U.S. Pipe Valve & Hydrant. Please see www.muellerwp.com/about to learn more.

Copyright © 2018 Henry Pratt Company, LLC. All Rights Reserved. The trademarks, logos and service marks displayed in this document are the property of Mueller Water Products, Inc., its affiliates or other third parties. Products above marked with a section symbol (§) are subject to patents or patent applications. For details, visit www.prattvalve.com. These products are intended for use in potable water applications. Please contact your Mueller Sales or Customer Service Representative concerning any other application(s).

F 13286 11/18

