

PRATT®

a **MUELLER** brand

LVC STEM COVER Knife Gate Valve

FEATURES

- Stem covers protect the stem from falling debris and are not necessarily dust tight. For dust tight covers, consult the factory.
- **NOTE:** The lower stem cover may reduce the opening stroke of the valve.

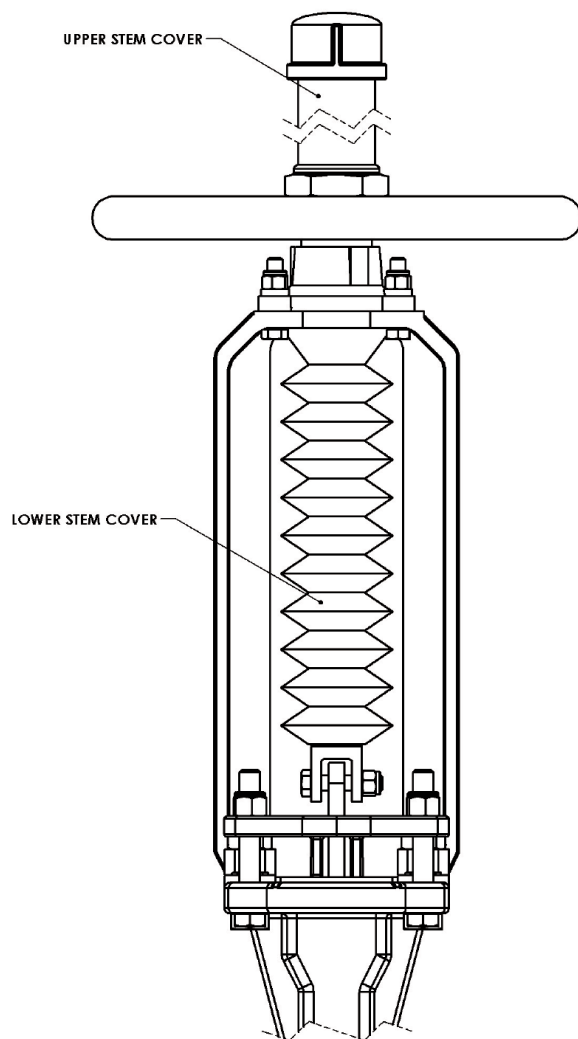

MUELLER

STEM EXTENSION COMPOSITE

NOTES

In order to properly design and price a stem extension assembly certain details must be provided by the customer. They are:

1. 'X' distance from centerline of valve to base of floorstand or top of floor.
 2. 'Y' distance from centerline of valve to base of stem guide, or wall.
 3. Maximum differential pressure of valve requirements.
- A. Consult factory before using assemblies in detail 'C' & 'G.'
- B. Floor structure must withstand valve thrust in detail 'D.'
Contact factory for valve thrust requirements.

Due to the many variables involved with stem extension design and pricing, it is recommended that you contact the factory to confirm selection. Please reference assembly preferred, dimension as required, valve type and maximum differential pressure of valve to be used.

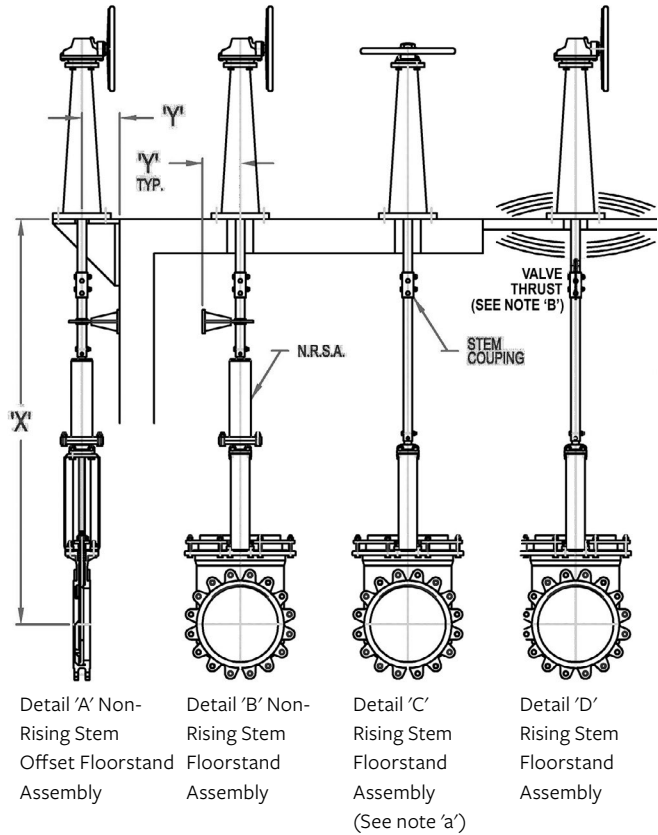

- N. = NON
- R. = RISING
- S. = STEM
- A. = ADAPTER

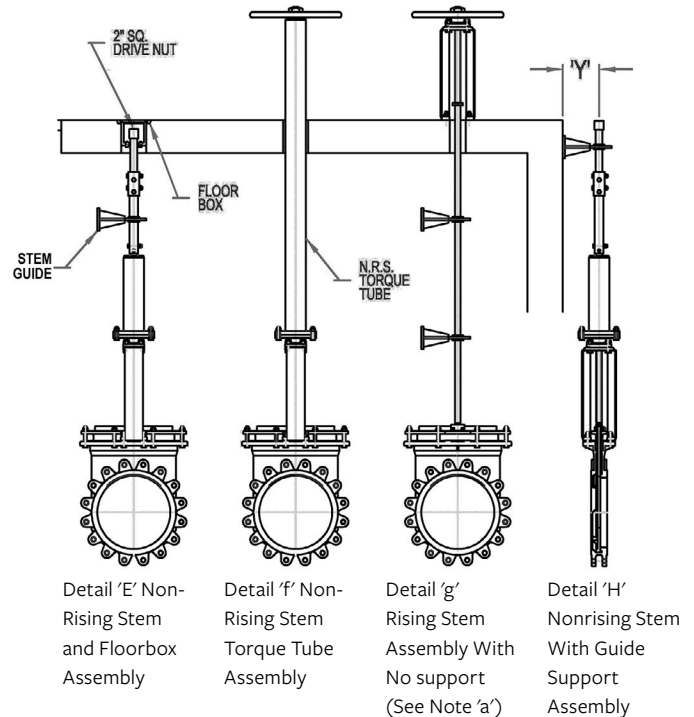

675 Mitchell Avenue, Woodland, WA 98674, moreinfo@prattvalve.com, P: 800.423.1323

Mueller refers to one or more of Mueller Water Products, Inc., a Delaware corporation ("MWP"), and its subsidiaries. MWP and each of subsidiaries are legally separate and independent entities when providing products and services. MWP does not provide products or services to third parties. MWP and each of its subsidiaries are liable only for their own acts and omissions and not those of each other. MWP brands include Mueller®, Echologics®, Hydro Gate®, Hydro-Guard®, Jones®, MiNet®, Milliken®, Pratt®, Singer®, and U.S. Pipe Valve & Hydrant. Please see www.muellerwpp.com/about to learn more.

Copyright © 2018 Henry Pratt Company, LLC. All Rights Reserved. The trademarks, logos and service marks displayed in this document are the property of Mueller Water Products, Inc., its affiliates or other third parties. Products above marked with a section symbol (§) are subject to patents or patent applications. For details, visit www.mwppat.com. These products are intended for use in potable water applications. Please contact your Mueller Sales or Customer Service Representative concerning any other application(s).

