

PRATT[®]

a **MUELLER** brand

RECTANGULAR BUTTERFLY VALVES

Engineering Creative Solutions for Fluid Systems Since 1901



MUELLER

PRATT®

a MUELLER brand

TABLE OF CONTENTS

Scope of Line	1
Material / Features and Benefits	2
Special Requirements	2
Design Details	3-4
Jack Bolt Mounting System	5
Wall Thimble Mounting System	6
Valve Dimensions	
Three-sided Rectangular Butterfly Valve	8
Four-sided Rectangular Butterfly Valve	9
Suggested Specification	10

RECTANGULAR BUTTERFLY VALVE

Scope of Line



APPLICATIONS

- Water Filtration Plants
- Sewage Treatment Plants
- Flood Control
- Power Plants
- Industrial Applications

DESCRIPTION

SIZES	3 ft. by 3 ft. up to 12 ft. by 12 ft. Consult factory for larger sizes.
BODY STYLES	Three or four-sided, in the following end configurations: <ul style="list-style-type: none">• Weld End• Flanged• Jack Bolt
PRESSURE RATINGS	<ul style="list-style-type: none">• Standard operating pressure differential is 10 psig.• Designs available from vacuum to 25 psig differential
SEAT	<ul style="list-style-type: none">• Rubber seat-in-body• Mounted on four sides or three sides (open top)
ACTUATION OPTIONS	<ul style="list-style-type: none">• Pratt® MDT manual actuator with handwheel or chainwheel• Electric actuator• Worm gear actuator
SERVICE	Distribution, potable or raw water
ACCESSORIES / OPTIONS	<ul style="list-style-type: none">• Position indicators• Extension bonnets• Limit switches• Speed control devices• Pressure switches• Push button controls Consult factory for accessory details.

MATERIAL SPECIFICATIONS

BODY MATERIAL	Carbon Steel – ASTM A36
DISC MATERIAL	Carbon Steel – ASTM A36
DISC EDGE	304 Stainless Steel – ASTM A276
SHAFT MATERIAL	304 Stainless Steel – ASTM A276
BEARING MATERIAL	Teflon-lined, Fiberglass-backed

For other available materials, consult factory.

RECTANGULAR BUTTERFLY VALVE

Design Details

MATERIAL SPECIFICATIONS - 1101

BODY	Carbon Steel
DISC	Carbon Steel
DISC EDGE	304 Stainless Steel
SHAFT	304 Stainless Steel
SEAT	Buna-N
BEARING	Duralon
PACKING	Chevron V-Type

FEATURE	BENEFIT
Rubber seat-in-body	Reduces seat failure due to corrosive buildup. Seat can be adjusted or replaced from both sides of disc (as an option) in the field in most cases without removing the valve from the line.
Thrust bearing located in the top trunnion	The two-way thrust bearing is fully accessible from the top of the valve if adjustment should ever be necessary.
Uninterrupted seat configuration	Bubble tight closure in both directions assured by means of a stainless steel disc edge closing onto a rubber seat.
90-degree turn to go from full open to fully closed	Easier to operate. Typically can be operated with one-tenth the number of turns required to achieve the same effect with a slide valve in the same service.
Simplified means of operation with reduced space requirements	Compact design requires less than one-half of the overhead operating clearance required for a slide valve.
Nonmetallic bearings	Prevents galvanic corrosion and provides lower coefficient of friction.
Sensitive flow control	Excellent for throttling or modulating service versus slide valve designs that do not adapt well to throttling service.
No metal-to-metal contact on seating surface	Excellent wearing qualities versus the typical slide valve which depends on the disc sliding on the seat and guide.
Jack bolt mounting	Ease of installation. Valve can be installed after channel is completed.

SPECIAL REQUIREMENTS

Whatever the application, the rectangular butterfly valve can be manufactured to meet your specific size, location and operating requirements. If manual actuation is required, we can supply a Pratt® MDT with a handwheel, chainwheel or a worm gear actuator. When automatic actuation is required, we can provide an electric actuator, or a pneumatic or hydraulic cylinder actuator, with or without manual override for open/close service, throttling or modulating service. Regardless of type, actuators may be mounted in a variety of positions for maximum convenience in installation and operation. All Pratt actuators are designed for long life with minimal maintenance, backed by decades of experience and industry know-how.

RECTANGULAR BUTTERFLY VALVE

Design Details

FOUR SIDED VALVE

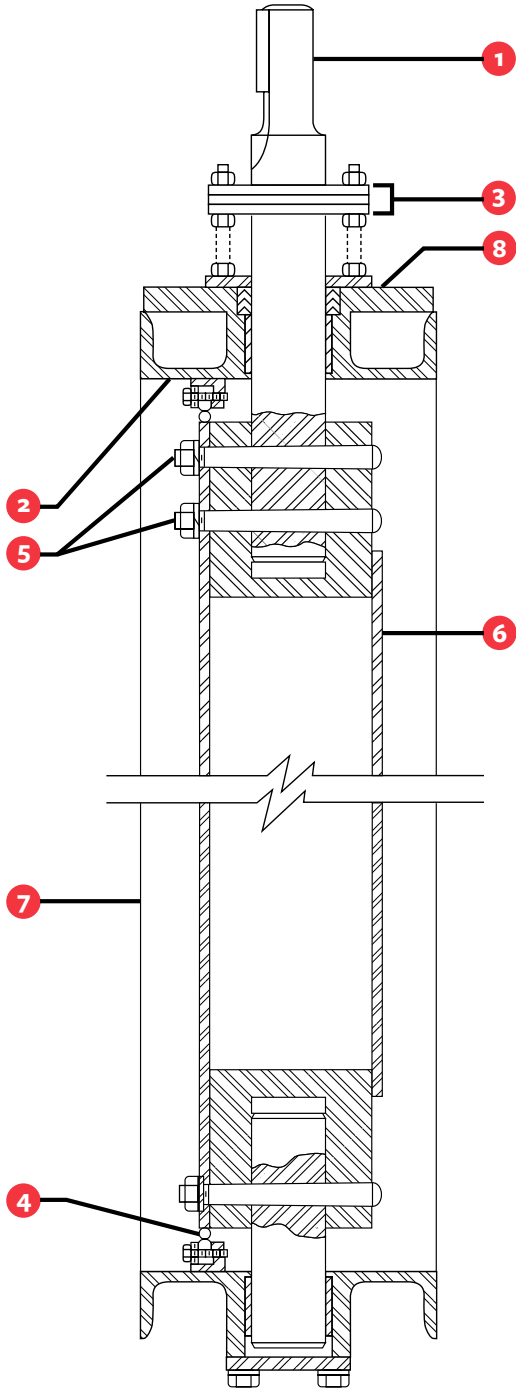

Tight Seal on 4 Sides

THREE-SIDED GATE

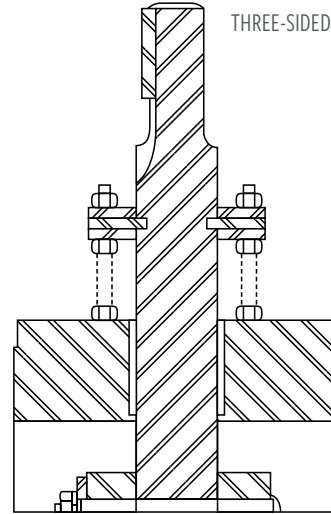

Tight Seal on 3 Sides

RECTANGULAR BUTTERFLY VALVE

Design Details

1 CORROSION RESISTANT SHAFTS

To prevent corrosion of a vital structural component, shafts are constructed of centerless ground, ASTM A276, Type 304 stainless steel bar -- not carbon steel or similar materials that afford no protection against the harmful effects of corrosion. Our standard line consists of a two-piece, stub type shaft keyed actuator connection.

2 PACKING (FOR FOUR-SIDED VALVES)

Packing is of the self adjusting "V" type. A packing gland or shaft seal is utilized only in the top trunnion of the valve body where the shaft protrudes for actuator connection. The packing assembly incorporates a nylon packing retainer followed by several rings of packing. It is readily accessible without having to dismantle the valve.

3 BEARINGS

Self lubricating sleeve type bearings are used in both trunnions of the valve body. Bearings support the shaft and provide minimum friction during shaft rotation. Size and quantity of bearings are dependent on shaft diameter and valve pressure rating. Bearing material is of a Teflon lined, fiberglass backed compound called Duralon. This type of bearing offers electrical insulating qualities between the shaft / disc assembly and the valve body, thereby eliminating the possibility of galvanic corrosion. In addition to the bearings' inherent protection against corrosion, its reduced coefficient of friction requires far less operating torque than the bearing materials used in the past.

4 RUBBER SEAT

The seat is constructed of a specially compounded synthetic rubber chosen carefully for the type of service typically required of Pratt® butterfly valves. The 50 durometer material is highly resistant to abrasion and chosen for long life without leakage. The seat is fully adjustable and field replaceable without dismantling the actuator, disc or shaft. It is retained in the body by ASTM A276, 18-8 Type 304 stainless steel segments and screws to ensure bubble tight closure after many years of demanding service.

5 TAPER PINS

The disc-to-shaft connection is accomplished by conservatively sized stainless steel taper pins, threaded at one end and secured with lock washers and nuts. Through-pin design, with two pins at the top and one at the bottom, provides the tightest possible connection between the shaft and disc. This gives one-piece rigidity to the connection.

6 DISC

The disc is constructed of ASTM A36 carbon steel with an ASTM A276, Type 304 stainless steel seating edge. It features stress safety factors of three on the yield and five on the ultimate strength of the material. The disc is of a streamline design to prevent turbulence in the full open position and to minimize pressure drop across the valve. It also provides excellent throttling characteristics.

7 BODY

The body is fabricated of carbon steel containing the seat assembly. It is designed for either wall mounting, channel mounting or installation in steel ducting.

8 THRUST BEARING ASSEMBLY

Located in the top trunnion, the 2-way thrust bearing is fully accessible from the top of the valve, if adjustment should ever be necessary. When the valve is installed in open channels, it is unnecessary to have special framing of concrete shapes at the bottom of the channel for access.

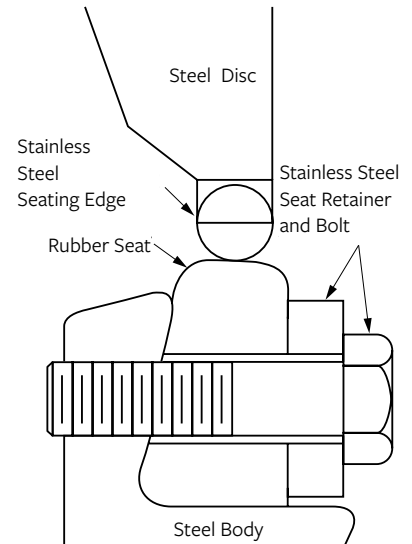

The seat is retained in the valve body by stainless steel segments and screws. Seat adjustment up to 1/4" is possible to ensure bubble tight closure over the life of the valve.

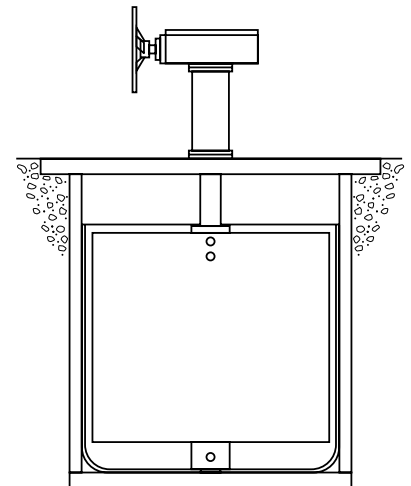

The three-sided rectangular butterfly valve features sealing surfaces on the bottom and both sides for installation in open channels. A bridge structure across the top is supplied to support the valve actuator. Cost reductions can be realized with this version since it eliminates much of the hardware and setup required for seal arrangements.

Jack Bolt Mounting System

SIMPLE AND COST EFFECTIVE MOUNTING

Jack bolt installation is simple, fast and economical. In this method, a channel is cast into concrete to the approximate outside dimensions of the valve. A steel channel section may also be furnished to provide for existing channel installation. The valve need not be present at the job site for this operation to be completed.

Jack bolt installation of a rectangular butterfly valve is accomplished by placing the complete valve, including actuator, into a cast channel. Jack bolts, which have been screwed into the valve body, are then turned out until the valve is tightly in place. The opposite end of the valve bears against a rubber gasket.

If a steel channel has not been imbedded into the concrete, the jack bolts are turned out against a steel bearing plate that can be supplied by us and put in place when the valve is installed. No further on site assembly is required.

In addition to minimizing the cost of installation, this method allows the user the ability to rapidly and inexpensively remove the valve from the channel if required for plant modifications.

This installation method does not require bolting to a thimble and eliminates the need for (and cost of) a thimble or mounting frame. Concrete work need not be delayed while waiting for frames or other hardware to arrive at the job site, making jack bolt mounted Pratt® rectangular butterfly valves less costly and easier to install than other similar products.

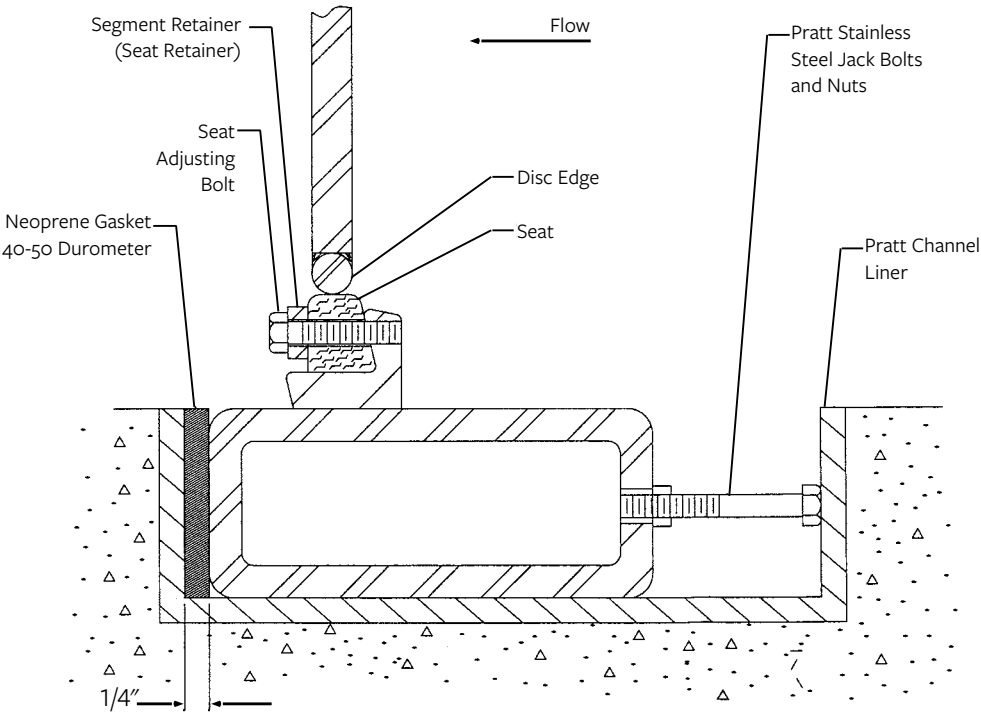

JACK BOLT INSTALLATION DETAIL

RECTANGULAR BUTTERFLY VALVE

Wall Thimble Mounting System

A MOUNTING METHOD TO MEET YOUR REQUIREMENTS

Two methods of wall mounting are available. One employs a double flange thimble, the other a single flange thimble. Both thimbles are of fabricated steel construction.

With the double flange thimble, one flange of the thimble is imbedded in the concrete while the valve bolts to the other flange. No keys or anchors are necessary.

With the single flange thimble, anchors or keys are welded around the periphery of the flangeless end and bolts are welded to the flange end. Concrete is poured around the flangeless end and the anchors or keys provide firm positioning. With this method, the valve is nearly flush with the wall.

Whichever mounting method is employed, the rectangular butterfly valve provides long life, quality of workmanship and superior design features to meet your plant's special flow control requirements.

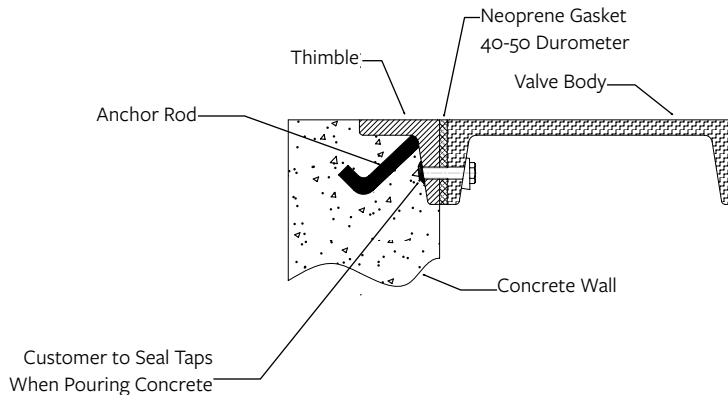

Typical Rectangular Valve with single flange thimble installation.

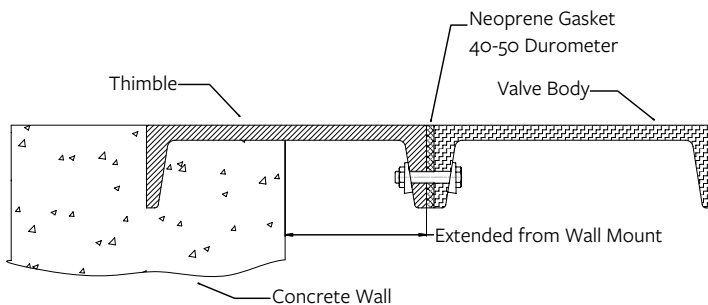

Typical Rectangular Valve with "C" (double flange) thimble installation.

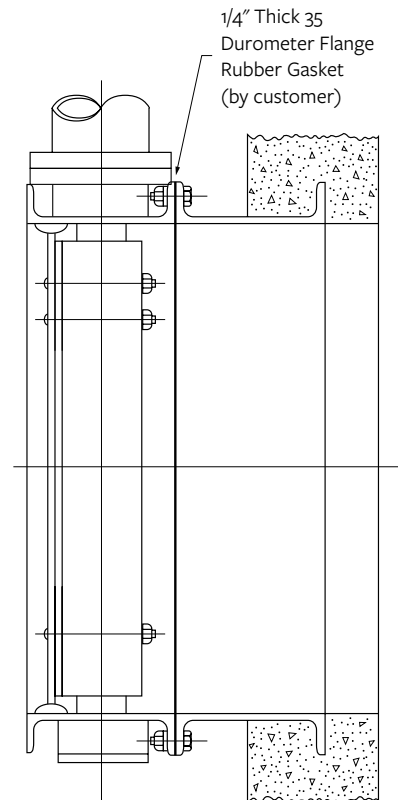

Water Flow Characteristics

As with all of our products, the Pratt® rectangular butterfly valve was tested in our laboratory to determine the flow characteristics of the valve in the full open position. We perform this testing to help our customers meet their special operating requirements. The following information represents the flow characteristics of the sizes most commonly ordered. (valve sizes shown in inches)

FULL OPEN Cv VALUES (x1000)

DIMENSIONS	30	36	42	48	54	60
30	67.5	81.0	94.5	108.0	121.5	135.0
36	81.0	97.2	113.4	129.6	145.8	162.0
42	94.5	113.4	132.3	151.2	170.1	189.0
48	108.0	129.6	151.2	172.8	194.4	216.0
54	121.5	145.8	170.1	194.4	218.7	243.0
60	135.0	162.0	189.0	216.0	243.0	270.0

NOTES: G = number of 3/4 inch diameter bolts required and K = shaft size.
Dimensions shown in inches; For additional information regarding flow characteristics, please consult factory; Cv values for other valve sizes available upon request.

RECTANGULAR BUTTERFLY VALVE

Dimensional Data

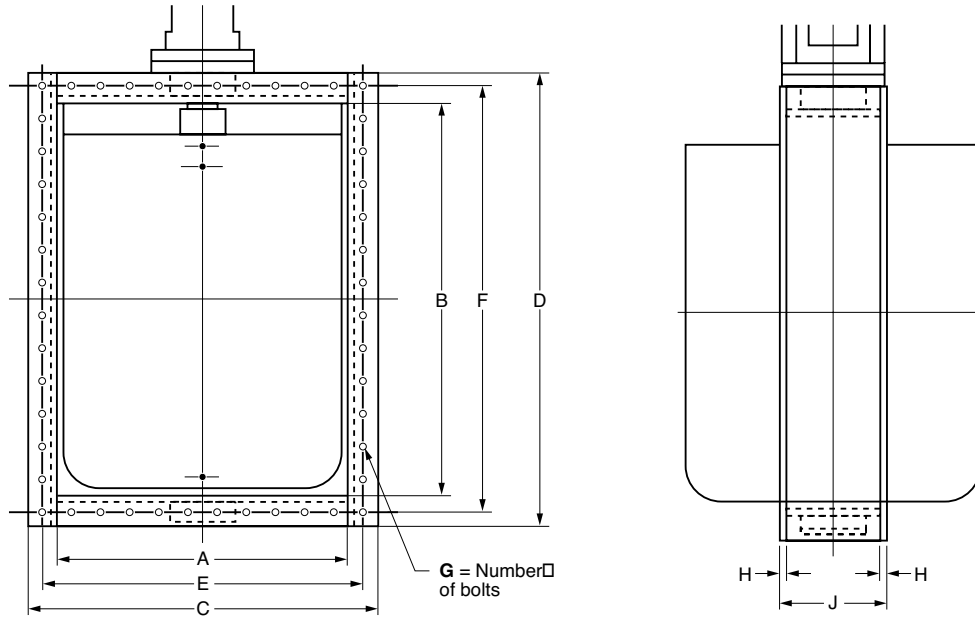

THREE-SIDED RECTANGULAR BUTTERFLY VALVE DIMENSIONS

VALVE SIZE (WIDTH X HEIGHT)	A	B	C*	D*	E	F	G	H	J	K
36 x 36	36	36	42	42	39 1/2	39 1/2	DETERMINED ON APPLICATION	1/2	12	3 1/4
48 x 48	48	48	54	54	52	52		1/2	12	3 1/4
60 x 60	60	60	66 3/4	66 3/4	64	64		5/8	15	3 1/4
60 x 72	60	72	66 3/4	78 3/4	64	76		5/8	15	3 5/8
72 x 96	72	96	80	104	77	101		5/8	18	4 7/8
84 x 108	84	108	92 1/2	116 1/2	89	113		5/8	18	5 3/8
144 x 144	144	144	152	152	149	149		5/8	18	5 7/8

NOTES: Dimensions shown in inches; G = number of 3/4" diameter bolts required; K = shaft size.
*C and D dimensions may vary with pressure and size of valve when jack bolt mounting is specified.

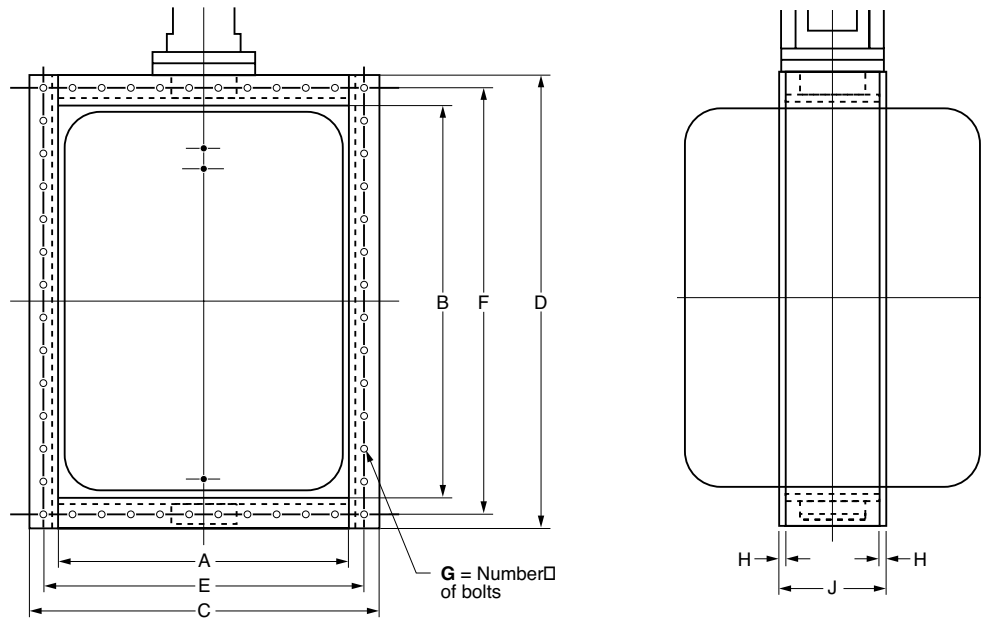

FOUR-SIDED RECTANGULAR BUTTERFLY VALVE DIMENSIONS

VALVE SIZE (WIDTH X HEIGHT)	A	B	C*	D*	E	F	G	H	J	K
36 x 36	36	36	42	42	39 1/2	39 1/2	DETERMINED ON APPLICATION	1/2	12	3 1/4
48 x 48	48	48	54	54	52	52		1/2	12	3 1/4
60 x 60	60	60	66 3/4	66 3/4	64	64		5/8	15	3 1/4
60 x 72	60	72	66 3/4	78 3/4	64	76		5/8	15	3 5/8
72 x 96	72	96	80	104	77	101		5/8	18	4 7/8
84 x 108	84	108	92 1/2	116 1/2	89	113		5/8	18	5 3/8
144 x 144	144	144	152	152	149	149		5/8	18	5 7/8

NOTES: Dimensions shown in inches; G = number of 3/4" diameter bolts required; K = shaft size.
 *C and D dimensions may vary with pressure and size of valve when jack bolt mounting is specified.

RECTANGULAR BUTTERFLY VALVE

Suggested Specifications

GENERAL

All rectangular butterfly valves shall be rubber seated and shall be ___in height and ___in width. They shall be bubble tight at rated pressures with flow in either direction. Valve design shall be suitable for an operating differential pressure of 10 psig maximum. They shall be capable of valve operation after long periods of inactivity. Valve discs shall rotate 90 degrees from the full open position to the tight shut position. When subjected to the maximum design head, a stress safety factor of 3.0 on the yield point or 5.0 on ultimate strength, whichever is the lower, shall not be exceeded. Maximum deflection of the valve structural design limit shall be 1/16 inch. Because of the nature of the service, experimental units or developmental designs will not be allowed. Bidders shall demonstrate a minimum of 5 years successful operation in installations and shall submit a list of such installations upon request. Valves shall be as manufactured by us.

VALVE BODY AND FLANGES

The valve body shall be a rectangular fabrication of carbon steel ASTM A36. Upper trunnion shall be recessed and bored for chevron V-type packing. Valve bodies shall be designed for wall mounting to existing wall thimble or jack bolt mounting.

VALVE DISC

The valve disc shall be fabricated of carbon steel with a stainless steel seating edge. Seating edge shall be ASTM A276 Type 304 stainless steel and shall be ground, polished and contoured. Leakage at corners under specified conditions or tests shall be cause for rejection. Disc shall be streamlined in shape to prevent turbulence in the full open position and to minimize pressure drop across the valve. Exposed disc rib stiffeners are not acceptable.

VALVE SEAT

The valve seat shall be contained in the body of the valve. Retaining segment and retaining screws shall be of ASTM A276 Type 304 stainless steel. The seat shall be a 50 durometer synthetic rubber compound. Seat adjustment possible and inherent in the design shall not be less than 1/8 inch. Valve seats shall be fully field adjustable and replaceable without dismantling the actuator,

disc or shaft. The valve manufacturer shall certify that the rubber seat is fully field adjustable and replaceable without the use of special tools or processes, as well as adjustable from both sides of the disc.

VALVE SHAFTS

Valve shafts shall be the stub type with shafts extending into the disc for a minimum distance of at least 1.5 shaft diameters. Shafts shall be securely locked to the disc by stainless steel taper pins. Shaft material shall be ASTM A276, Type 304 stainless steel.

VALVE BEARINGS

Main shaft bearings shall be Teflon lined, fiberglass backed sleeve type fitted into each valve body trunnion bore. Unit bearing stress shall not exceed 4000 psi. Each valve assembly shall be furnished with a 2-way thrust bearing assembly designed to hold the disc centered in the valve seat at all times. Thrust bearing shall be secured by a locking device, located in the top trunnion of the valve body and easily accessible for field adjustment from the actuator end of the valve.

INSTALLATION

Valves designed for channel installation shall be installed to provide a means of removing the complete valve assembly without dismantling the valve or actuator. Installation methods that employ permanent, multiple bolting shall not be acceptable for channel mounting. Valves designed for wall mounting shall have flanges drilled in accordance with the template of a frame or casting to which it is bolted. Valves installed in ducting shall have body flanges suitable for welding to steel ducting or drilled for bolting to duct flanges.

PAINTING

Two coats of paint shall be applied to the inside and outside surfaces of the valve body and the outside surfaces of the disc, except finished surfaces, bearing surfaces and the stainless steel seat retainers and disc edge. The paint shall be either asphalt varnish (per Federal Specifications TT-C494A) for sewage service or where additional protection is desired. Rust inhibitive alkyd primer shall be applied for fresh water, steam or air service.

NOTES

NOTES

NOTES

PRATT® Product Guide

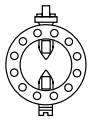

MODEL 2FII



MONOFLANGE MKII

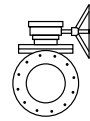

PLUG VALVES

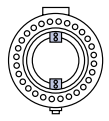

TRITON® XR70

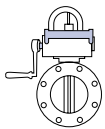

INDICATING BUTTERFLY VALVES UL & FM APPROVED

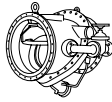

TILTING DISC CHECK VALVES

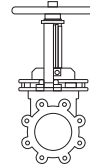

KNIFE GATE VALVES

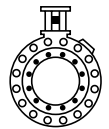

N-STAMP NUCLEAR BUTTERFLY VALVES

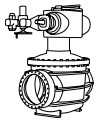

CONE VALVES

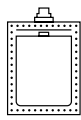

RECTANGULAR

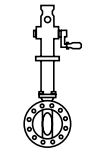

PIVA POST INDICATING VALVES ASSEMBLY UL & FM APPROVED

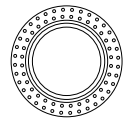

SLEEVE VALVES

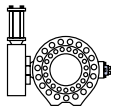

RUBBER SEATED BALL VALVES

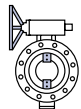

TRITON® 250

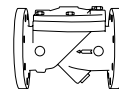

CHECK VALVES

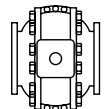

METAL SEATED BALL VALVE



CONTROL SYSTEMS

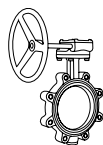

INDUSTRIAL VALVES

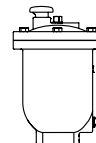

AIR VALVES

For more information about us or to view our full line of water products, please visit www.prattvalve.com or call Pratt customer service at 1.800.423.1323.

Mueller refers to one or more of Mueller Water Products, Inc., a Delaware corporation ("MWP"), and its subsidiaries. MWP and each of its subsidiaries are legally separate and independent entities when providing products and services. MWP does not provide products or services to third parties. MWP and each of its subsidiaries are liable only for their own acts and omissions and not those of each other. MWP brands include Mueller®, Echologics®, Hydro Gate®, Hydro-Guard®, Jones®, Mi.Net®, Milliken®, Pratt®, Singer®, and U.S. Pipe Valve & Hydrant. Please see www.muellerwp.com/about to learn more.

Copyright © 2018 Henry Pratt Company, LLC. All Rights Reserved. The trademarks, logos and service marks displayed in this document are the property of Mueller Water Products, Inc., its affiliates or other third parties. Products marked with a section symbol (§) are subject to patents or patent applications. For details, visit www.mwppat.com. These products are intended for use in potable water applications. Please contact your Mueller Sales or Customer Service Representative concerning any other application(s).