

# PRATT®

a **MUELLER** brand

## TILTING DISC CHECK VALVE

Engineering Creative Solutions for Fluid Systems Since 1901



**MUELLER**

## TABLE OF CONTENTS

Design Details..... 1  
 Features and Benefits..... 1  
 Suggested Specifications.....2  
 Dimensional Data .....2-4

### INTRODUCTION

The Pratt® Tilting Disc Check Valve is the most versatile and reliable check valve we have to offer. This valve offer significant energy and cost savings over the life of the valve due to its large flow area and low head loss characteristics. Short disc travel from full open to full close provides the ability to close very rapidly or very slowly to avoid contributing to slamming and surges. The tilting disc check valve is also offered with an upper hydraulic dashpot to aid in disc closure in multiple pump systems even after a power failure. We continue to expand our product offering to those customers who require specialty valves for applications where opening and closing times are critical to control flow reversal and reduce water hammer.

### SCOPE OF LINE

- Available in sizes 4 inches through 60 inches
- Various end configurations available
- Ductile iron body, disc and cover
- Stainless steel disc and body seat rings
- Stainless steel hinge pin
- Other materials available upon request
- Rated working pressure 250 psi

### LOW HEADLOSS DESIGN ADVANTAGE

The Pratt Tilting Disc Check Valve offers significant energy savings compared to other types of conventional check valves because of its larger flow area and low head loss characteristics. The valve achieves full opening when the disc “tilts” in the flow of the media. The tilting disc design through lifting and stabilizing in the full-open position, provides minimal flow resistance.

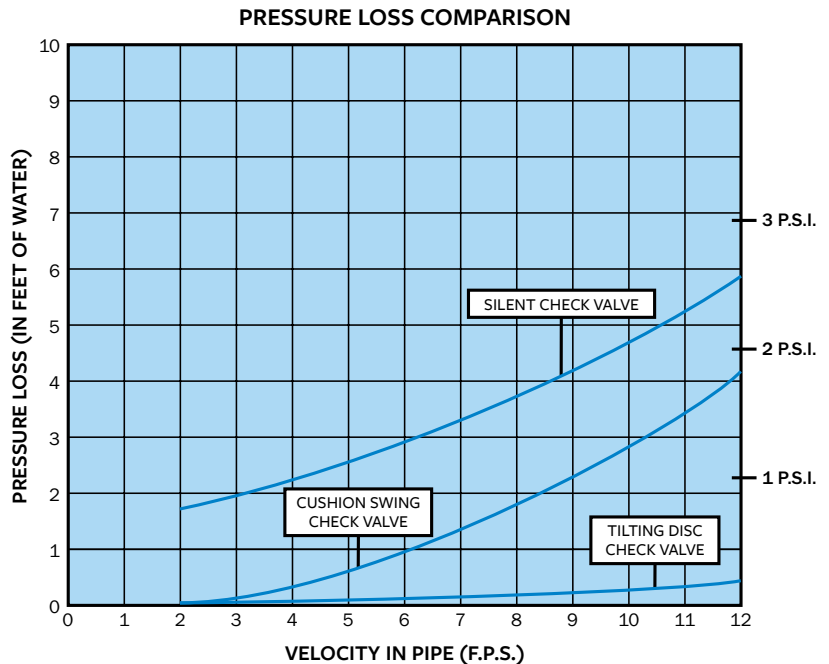

# TILTING DISC CHECK VALVE

## Overview



### DESIGN DETAILS

<b>BODY MATERIAL</b>	Ductile Iron ASTM A536 Gr. 65-45-12
<b>DISC MATERIAL</b>	Ductile Iron ASTM A536 Gr. 65-45-12
<b>COVER</b>	Ductile Iron ASTM A536 Gr. 65-45-12
<b>DISC SEAT RING</b>	Stainless Steel ASTM A269 Type 304
<b>BODY SEAT RING</b>	Stainless Steel ASTM A269 Type 304
<b>HINGE PIN</b>	Stainless Steel ASTM A269 Type 304
<b>BEARING BUSH</b>	Bronze B62

Other materials available upon request.

### FEATURE

### BENEFIT

Variable opening and closing speeds	<ul style="list-style-type: none"><li>• Short disc travel from full open to full close provides the ability to close very rapidly or very slowly to avoid contributing to slamming and surges.</li></ul>
Cushioned closure	<ul style="list-style-type: none"><li>• Action of the fluid on the disc is balanced due to pivot points that allow for cushioned movement of the disc into the seat.</li></ul>
Long body laying length	<ul style="list-style-type: none"><li>• Permits smooth passage of water with minimum turbulence and low potential for cavitation.</li></ul>
Low maintenance	<ul style="list-style-type: none"><li>• The stainless steel stub shafts do not come in contact with fluid and can be lubricated either manually or automatically.</li></ul>
Non-slam characteristics	<ul style="list-style-type: none"><li>• The design of the seat and hydraulic dashpot cushions the closing forces on the disc to allow for smooth operation. This prevents slamming of the disc into the seat.</li></ul>
Low headloss	<ul style="list-style-type: none"><li>• Minimal effort to keep the disc open is achieved through the balanced disc design that provides light weight lifting properties, which translates to minimal flow resistance.</li></ul>
Less risk of reverse flow	<ul style="list-style-type: none"><li>• Rapid closing of the disc decreases the chance of reverse flow to occur.</li></ul>

# TILTING DISC CHECK VALVE

## Dimensional Data

### DIMENSIONS

DIAMETER	FACE-TO-FACE LENGTH	APPROXIMATE WEIGHT
4"	11.5"	135 lbs.
6"	15"	160 lbs.
8"	19.5"	375 lbs.
10"	24.5"	330 lbs.
12"	24"	462 lbs.
14"	30"	771 lbs.
16"	30"	1062 lbs.
18"	33"	1200 lbs.
20"	32"	1652 lbs.
24"	38"	2368 lbs.
30"	52"	3525 lbs.
36"	59.5"	5177 lbs.
42"	60"	5727 lbs.
48"	65"	8745 lbs.
54"	70"	11345 lbs.

\* May vary with pressure

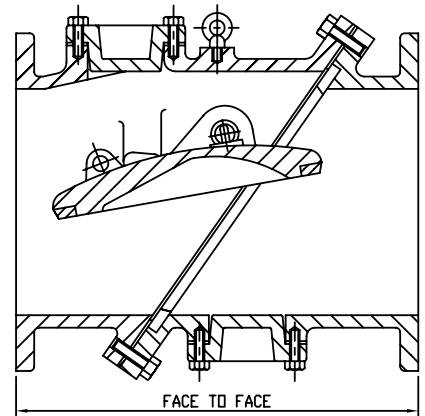
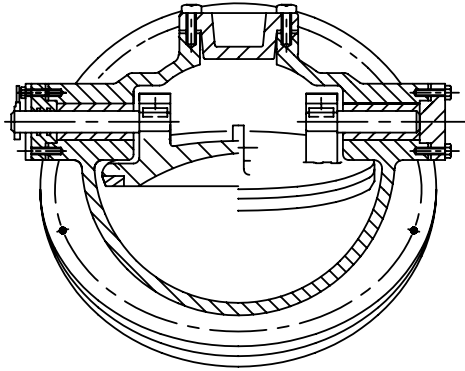

### SUGGESTED SPECIFICATIONS

#### GENERAL

The check valve shall be of the tilting disc type as manufactured by us. The tilting disc check valve shall consist of a circular disc with conical rim, hinged about a fixed pivot above its center-line and offset from the plane of the seat, sealing against a body seat clamped between the two sections of the valve body.

#### VALVE CONSTRUCTION

The body shall be two-piece, consisting of an entrance and a discharge section bolted together at an angle with the pipeline. An O-ring seal in a groove between the body flanges shall be in place to prevent leakage between the flanges when bolted together. The valve shall be complete with ANSI class flanges to mate with adjacent equipment.

A body seat shall be clamped in place in a slot between the two body sections. The body seat shall have a conical finish to mate with the disc seat. There shall be an inspection port provided in both the entrance and discharge sections to provide visual access both upstream and downstream of the disc. An indicator shall be provided to show disc position for the full range of travel. Bosses

shall be cast in both the entrance and discharge sections to allow for a top or bottom mounted oil dashpot for controlled opening and closing.

All valve castings shall be ductile iron ASTM A536 Grade 65-45-12. The disc and body seat ring shall be stainless steel ASTM A269 Type 304. The hinge-pin shall be stainless steel ASTM A276 Type 304. The bearing sleeve shall be Bronze B62.

#### TESTING

Seat and leakage testing shall be in strict accordance with AWWA Standard C-508 latest edition for Swing Check Valves. Rated working pressure of the check valve line is 250 psi.

#### COATING

Coating shall be a NSF61 approved epoxy.

*We reserve the right to change parts and components to improve product performance.*

# TILTING DISC CHECK VALVE

## Dimensional Data

### 4" – 36" PRATT® TILTED DISC CHECK VALVE

SIZE		ANSI B16.1 CL.125						
ØD	L	ØD	ØC	ØH	N	T	A	H
4	11 1/2	9	7 1/2	3/4	8	15/16	13	10
6	15	11	9 1/2	7/8	8	1	16	13
8	19 1/2	13 1/2	11 3/4	7/8	8	1 1/8	19	16
10	24 1/2	16	14 1/4	1	12	1 3/16	23	18
12	24	19	17	1	12	1 1/4	26	21
14	30	21	18 3/4	11/8	12	1 3/8	29	23 3/4
16	30	23 1/2	21 1/4	11/8	16	1 7/16	32	26 3/4
18	33	25	22 3/4	11/4	16	1 9/16	36	30
20	32	27 1/2	25	11/4	20	1 11/16	39	32
24	38	32	29 1/2	13/8	20	1 7/8	46	37
30	52	38 3/4	36	13/8	28	2 1/8	54	47
36	59 1/2	46	42 3/4	15/8	32	2 3/8	64	51

\* May vary with pressure

These dimensions are correct at time of publication and are not to be construed as certified drawings. Certified drawings available upon request.

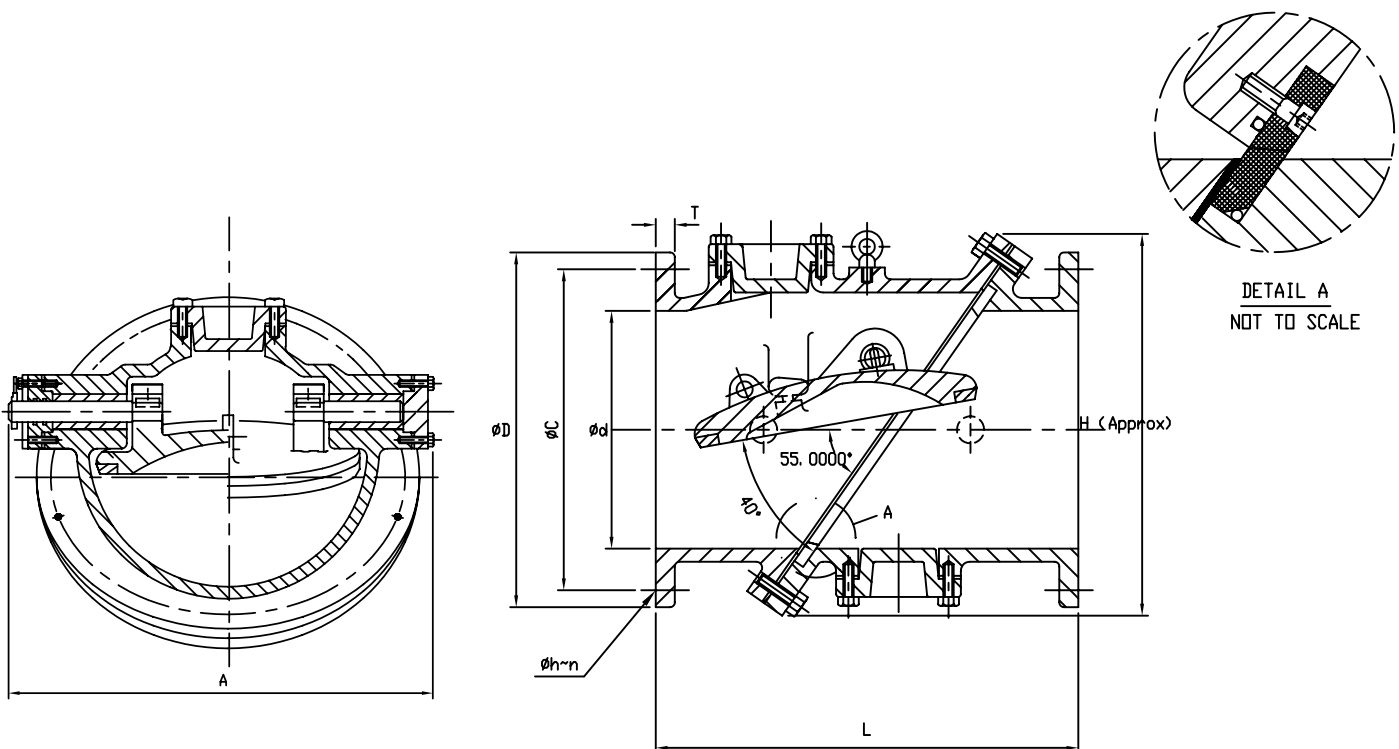



# TILTING DISC CHECK VALVE

## Dimensional Data

### 4" – 36" PRATT® TILTED DISC CHECK VALVE WITH DASHPOT

SIZE	ANSI B16.1 CL.125								
L	ØD	ØC	Øh	n	T	A	H	J	K
4	11 1/2	9	7 1/2	3/4	8	15/16	13	10	12
6	15	11	9 1/2	7/8	8	1	16	13	12
8	19 1/2	13 1/2	11 3/4	7/8	8	1 1/8	19	16	17
10	24 1/2	16	14 1/4	1	12	1 3/16	23	18	17
12	24	19	17	1	12	1 1/4	26	21	21
14	30	21	18 3/4	1 1/8	12	1 3/8	29	23 3/4	21
16	30	23 1/2	21 1/4	1 1/8	16	1 7/16	32	26 3/4	24
18	33	25	22 3/4	1 1/4	16	1 9/16	36	30	24
20	32	27 1/2	25	1 1/4	20	1 11/16	39	32	28
24	38	32	29 1/2	1 3/8	20	1 7/8	46	37	28
30	52	38 3/4	36	1 3/8	28	2 1/8	54	47	36
36	59 1/2	46	42 3/4	1 5/8	32	2 3/8	64	51	36

\* May vary with pressure

These dimensions are correct at time of publication and are not to be construed as certified drawings. Certified drawings available upon request.

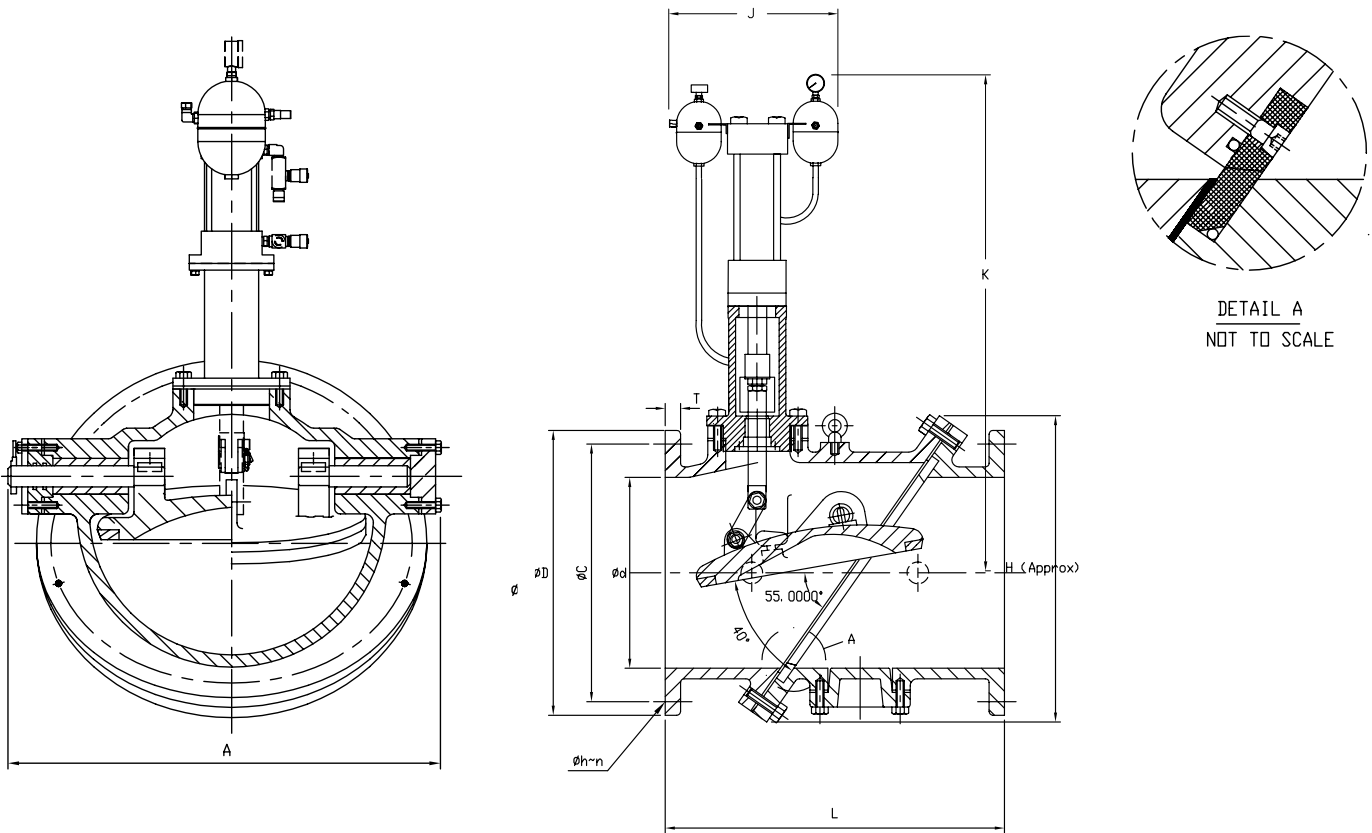

# NOTES

## PRATT® Product Guide

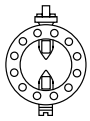

**MODEL 2FII**



**MONOFLANGE MKII**

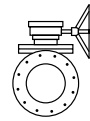

**PLUG VALVES**

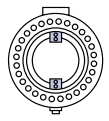

**TRITON® XR70**

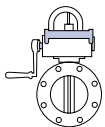

**INDICATING BUTTERFLY VALVES UL & FM APPROVED**

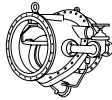

**TILTING DISC CHECK VALVES**

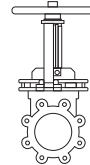

**KNIFE GATE VALVES**

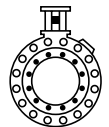

**N-STAMP NUCLEAR BUTTERFLY VALVES**

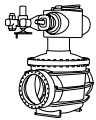

**CONE VALVES**

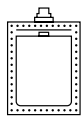

**RECTANGULAR**

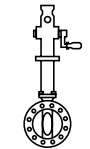

**PIVA POST INDICATING VALVES ASSEMBLY UL & FM APPROVED**

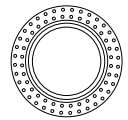

**SLEEVE VALVES**

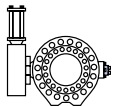

**RUBBER SEATED BALL VALVES**

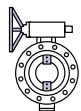

**TRITON® 250**

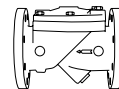

**CHECK VALVES**

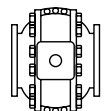

**METAL SEATED BALL VALVE**



**CONTROL SYSTEMS**

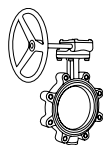

**INDUSTRIAL VALVES**

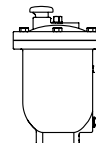

**AIR VALVES**

**For more information about us or to view our full line of water products, please visit [www.prattvalve.com](http://www.prattvalve.com) or call Pratt customer service at 1.800.423.1323.**

Mueller refers to one or more of Mueller Water Products, Inc., a Delaware corporation ("MWP"), and its subsidiaries. MWP and each of its subsidiaries are legally separate and independent entities when providing products and services. MWP does not provide products or services to third parties. MWP and each of its subsidiaries are liable only for their own acts and omissions and not those of each other. MWP brands include Mueller®, Echologics®, Hydro Gate®, Hydro-Guard®, Jones®, Mi.Net®, Milliken®, Pratt®, Singer®, and U.S. Pipe Valve & Hydrant. Please see [www.muellerwp.com/about](http://www.muellerwp.com/about) to learn more.

Copyright © 2018 Henry Pratt Company, LLC. All Rights Reserved. The trademarks, logos and service marks displayed in this document are the property of Mueller Water Products, Inc., its affiliates or other third parties. Products marked with a section symbol (§) are subject to patents or patent applications. For details, visit [www.mwppat.com](http://www.mwppat.com). These products are intended for use in potable water applications. Please contact your Mueller Sales or Customer Service Representative concerning any other application(s).