

- A. IGNORE SEAT SIDE DESIGNATION ON BFV SIZE 3" -20"
- B.
- C. CHECK WITH FACTORY WHEN SELECTING ALTERNATE MIRROR ACTUATOR STYLES.

PHANTOM LINES SHOW TRUNNION MODIFICATIONS TO THE FOLLOWING SIZE VALVE: 20" TAP 1-1/8"-7 UNC-2B X 1-1/2" DEEP 4-PLACES EACH FACE.

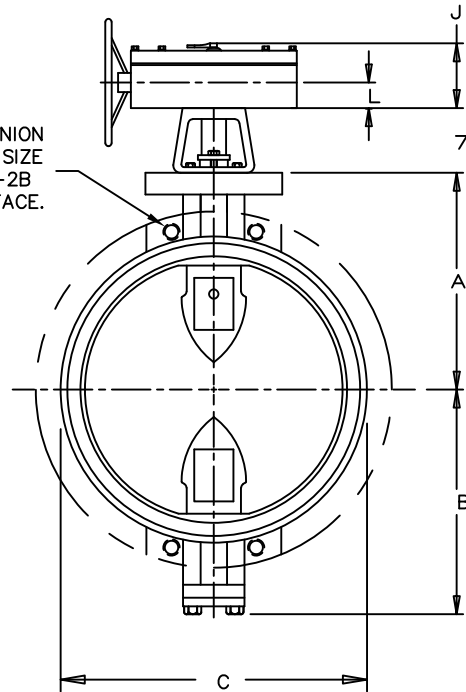

VALVE SIZE	DISC O. D.	MIN. MATING I. D.
3	3.087	2.41
4	4.072	3.44
6	6.068	5.38
8	8.076	7.53
10	10.096	9.62
12	12.106	11.64
14	13.337	12.86
16	15.334	14.79
18	17.368	16.75
20	19.385	18.71
24	23.100	22.28

NOTES:

1. ALL DIMENSIONS SHOWN IN INCHES.
2. "D" DIMENSION  $\pm 1/16$ " FOR 3" THRU 10" VALVES.  
"D" DIMENSION  $\pm 1/8$ " FOR 12" THRU 20" VALVES.
3. DIMENSION "C" ALLOWS CLEARANCE FOR 125 LB OR 150 LB A.S.A. BOLT LAYOUT.
4. VALVES MANUFACTURED & TESTED IN ACCORDANCE WITH AWWA SPECIFICATION C-504 LATEST REVISION, CLASS 150B.

VALVE SIZE	A	B	C	D
3	4-3/4	3-1/4	5-1/4	2-1/16
4	5-1/2	3-1/2	6-3/4	2-5/16
6	6-1/2	5-1/8	8-5/8	2-15/16
8	7-3/4	6-1/2	10-7/8	3-1/16
10	9	9-7/8	13-1/4	3-3/16
12	10-1/2	11-3/8	16	3-7/16
14	11-7/8	12-3/4	17-5/8	3-11/16
16	13-1/2	14-3/8	20-1/8	4-3/16
18	14-3/8	15-1/4	21-1/2	4-11/16
20	16	17	23-3/4	5-3/16
24	18-7/8	19-3/8	28-1/8	6-3/16

ACTUATOR SIZE	J	L	M	N	P	Q	R	S	T	V	W	NUMBER OF TURNS
MDT-2S	4-11/16	2	2-1/8	2	4-1/2	4-1/2	8-1/4	7-7/8	7-7/8	8	9-1/8	32
MDT-3S	5-5/8	2-7/16	3-1/4	3-5/32	5-5/8	5-3/8	10-3/8	10-1/2	10-1/8	12	9-1/8	30
MDT-4S	6-3/8	2-27/32	3-3/8	4	7-5/16	6-3/4	11-5/16	11-1/2	11	12	9-1/8	40
MDT-5	7-9/16	3-15/32	4-1/2	5-1/2	8-3/4	10	17	17 3/16	17-3/16	18	16-7/16	44

4/28/23	RTF	RF	UPDATED TEMPLATE & ADDED POSITION CHART									
REV.-DATE	BY	APP.	REVISION	REV.-DATE	BY	APP.	REVISION					