

# Multiport Plug Valve



## Construction Specifications:

**Sizes:** 3" through 16"

**Body:** Cast Iron

**Plug:** Ductile Iron

**Plug Coating:** Buna-N  
Neoprene  
EPDM

## Description

Combining simplicity of design with high quality manufacturing processes, the Pratt multiport plug valve provides high flow and large solids passage. A four inch multiport valve allows a 3" round solid to pass without compression. This fact permits smaller valves to be used without sacrificing flow integrity. In the unlikely event wear occurs between the plug face and the body seal, the plug can be adjusted externally with the turn of a wrench. The Pratt multiport valve is excellent for directional control applications. Drip tight shut-off is available by special request.

## Features

### Body

Plug valve body casting is of ASTM A-126 Class B iron using high pressure molding techniques for consistent quality and precision. Flange diameter, drilling and thickness conform to ANSI B 16.1 Class 125.

### Seat

The multiport valve employs a corrosion and abrasion resistant epoxy seat on all sizes.

### Stem Seal

Multiple self adjusting "U" cup seals are used to prevent stem leakage and provide years of trouble free service.

### Bearings

The plug rotates in oil impregnated sintered 316 grade stainless steel bearings located in both the body and bonnet.

### Plug

Supported on integral trunnions, the solid ductile iron tapered plug is faced with any of a variety of elastomers that are vulcanized in place and ground to size. Plug position and shut off is controlled by use of adjustment gland attached to the plug shaft

### Bonnet Seal

Superior "O" ring sealing with metal/metal contact means lower stresses compared to traditional compression gaskets.

### Flow

The wide port design with streamlined internal contours allows for a high capacity flow in the full open position reducing turbulence and pressure drop through the valve.

### Position Indication

Active port indication is standard on all wrench operated and gear operated multiport valves.

## Materials of Construction

No	Description	Material	Specification
1	Body	Cast Iron	ASTM A-126 CLB
2	Plug	Ductile Iron	ASTM A-536
3	Plug Coating	Elastomer	As specified
4	Bonnet	Cast Iron	ASTM A-126 CLB
5	Gland	Ductile Iron	ASTM A-536
6	Bearings	Stainless Steel	Sintered 316
7	Seals	Elastomer	As specified
8	Seat	Epoxy	-

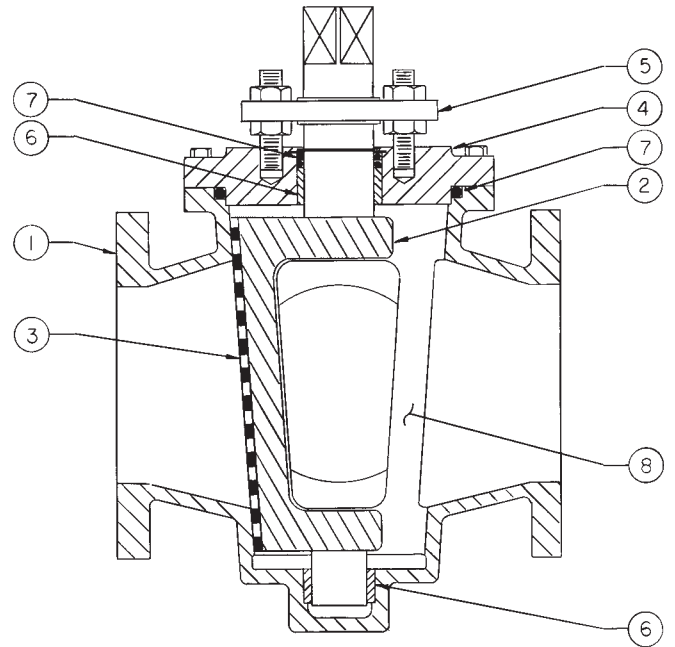

Flanges are per ANSI B16.1  
Class 125/150 Flat Faced

## Suggested Specification

Valves shall be of the three way non-lubricated type with an elastomer covering all seating surfaces of the tapered plug. The elastomer shall be suitable for the service intended. Flanged valves shall be manufactured in accordance with ANSI B16.1 including facing, drilling and flange thickness. Valves shall be designed for a working pressure of 175 psi.

Valve bodies shall be of ASTM A-126 Class B cast iron. Plugs shall be of ASTM A-536 Grade 65-45-12 ductile iron in compliance with AWWA C-504. The axial position of the plug shall be held in place by an adjustable gland. The valve shall operate without the need for lifting prior to turning the plug.

Valves shall be furnished with replaceable sleeve type bearings conforming to AWWA C-504 and AWWA C-507. Bearings shall be of sintered, oil impregnated type 316 stainless steel ASTM A743 Grade CF-8M. Valve shaft seals shall be of the "U" cup type in accordance with AWWA C-504. Seals shall be self adjusting and repackable without removing the bonnet from the valve.

Wrench operated valves shall be capable of being converted to worm gear or automated operation without removing the bonnet or plug from the valve. All wrench operated valves shall be equipped with a 2" square nut for use with removable levers or extended "T" handles.

Worm gear operator, where required, shall be of heavy duty construction with the ductile iron quadrant supported on top and bottom by oil impregnated bronze bearings. The worm gear and shaft shall be manufactured of hardened steel and run on high efficiency roller bearings. Worm gear operators shall require single handwheel only.

# Valve Patterns

## Three-Way Valve Port Positions

(View is from top of Valve)

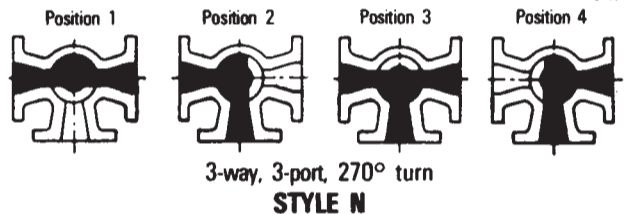
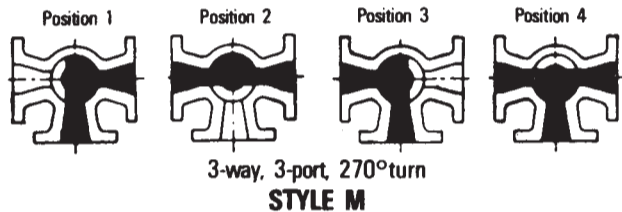
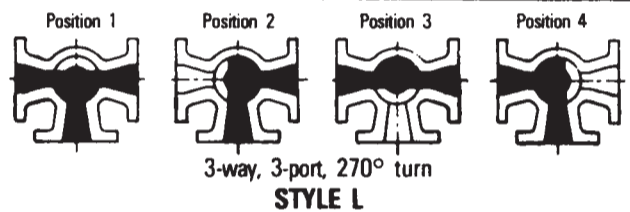
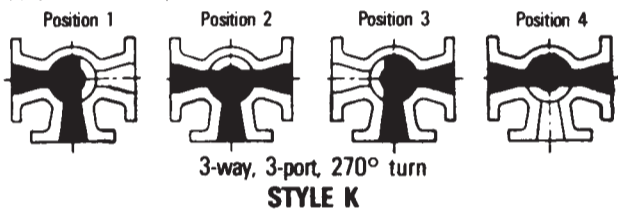
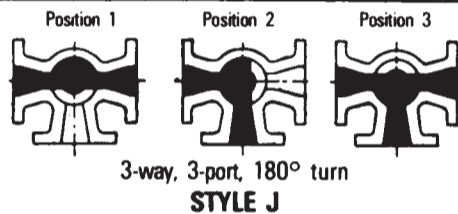
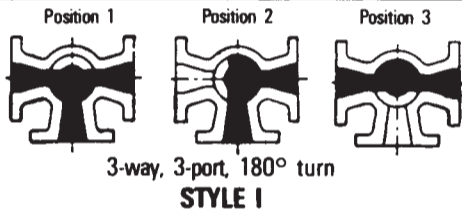
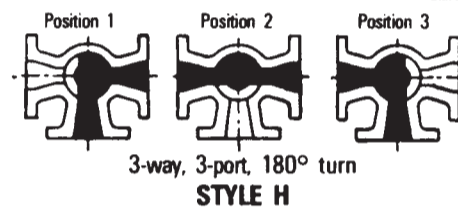
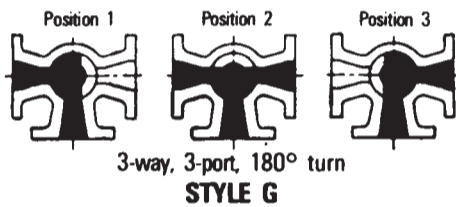
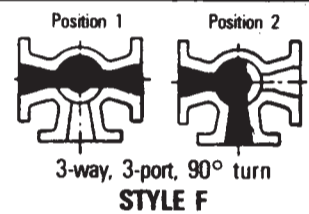
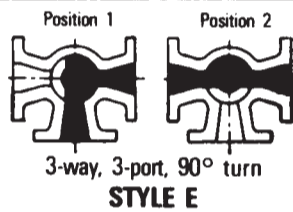
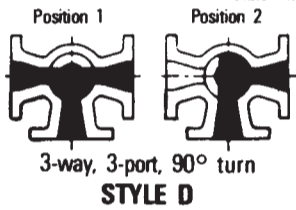
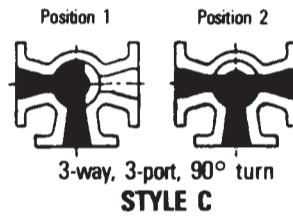
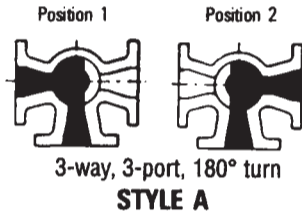

### HOW TO ORDER

When ordering three-way valves specify the size and figure number of the valve, plus the style letter of the port position desired.

# THREE WAY

175 P.S.I.

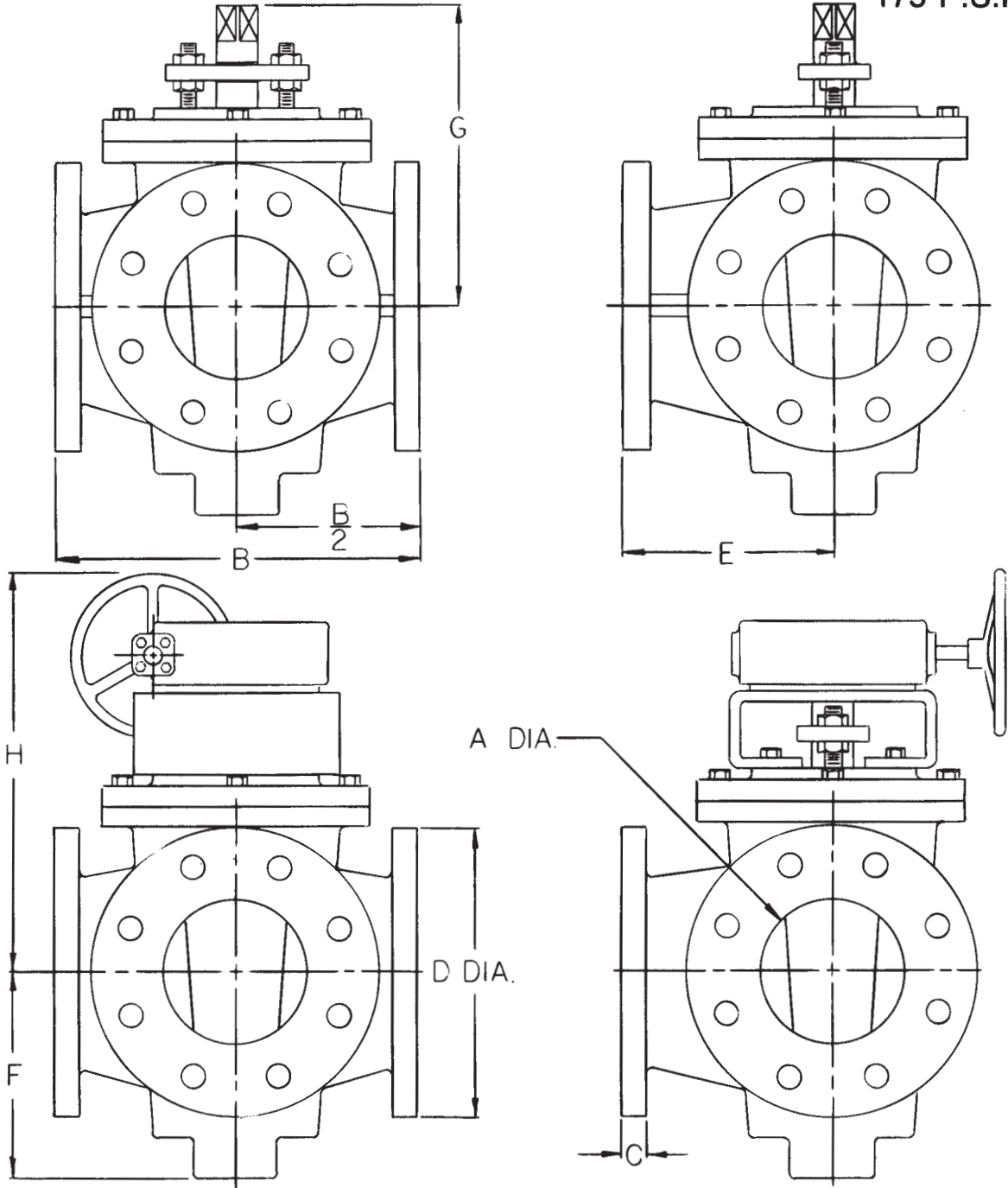

VALVE SIZE	A	B	C	D	E	F	G	H	WEIGHT	
									W.O.	G.O.
3"	3	8.00	.75	7.5	5.50	4.75	9.13	15.13	65	110
4"	4	9.88	.94	9.0	6.50	6.00	13.63	19.13	120	200
6"	6	11.63	1.00	11.0	8.00	7.06	15.13	20.38	170	250
8"	8	13.88	1.13	13.5	9.00	11.00	19.13	24.50	325	405
10"	10	16.75	1.19	16.0	11.00	11.00	19.13	24.50	380	460
12"	12	19.00	1.25	19.0	11.56	12.88	21.25	26.50	475	555
14"	14	21.00	1.38	21.0	12.50	14.38	N/A	29.00	N/A	937
16"	16	23.75	1.44	23.25	15.13	15.88	N/A	31.13	N/A	1053